

# CE-EMC TEST REPORT

**Prepared for :**

**EDA Technology Shanghai Co.,Ltd**

**Building 29, No.1661 Jialuo Road, Jiading District, Shanghai, PRC**

**Product Name: CM5 AI CAMERA**

**Trade Mark: EDATEC**

**Product Model (S): ED-AIC3100**

**Date of Test: Apr. 01, 2026 – Apr. 23, 2026**

**Date of Report: Apr. 23, 2026**

**Report Number: HK2604010381-1ER**

**Prepared By :**

**Shenzhen HUAKE Testing Technology Co., Ltd.**

**1-2/F., Building B2, Junfeng Zhongcheng Zhizao Innovation Park, Heping,**

**Fuhai Street, Bao'an District, Shenzhen, Guangdong, China**



### TEST REPORT VERIFICATION

Applicant : EDA Technology Shanghai Co.,Ltd

Address : Building 29, No.1661 Jialuo Road, Jiading District, Shanghai, PRC

Manufacturer : EDA Technology Shanghai Co.,Ltd

Address : Building 29, No.1661 Jialuo Road, Jiading District, Shanghai, PRC

Product Name : CM5 AI CAMERA

(A) Product Model : ED-AIC3100

(B) Series Model : N/A

(C) Power Supply : DC 24V From Adapter with AC 100-240V, 50/60Hz

**Standards** ..... EN 55032:2015 + A1:2020 + A11:2020  
 EN IEC 61000-3-2:2019 + A1:2021 + A2:2024  
 EN 61000-3-3:2013 + A1:2019 + A2:2021  
 EN 55035:2017+ A11:2020

This device described above has been tested by HUAKE, and the test results show that the equipment under test (EUT) is in compliance with the 2014/30/EU requirements. And it is applicable only to the tested sample identified in the report.

This report shall not be reproduced except in full, without the written approval of HUAKE, this document may be altered or revised by HUAKE, personal only, and shall be noted in the revision of the document.

Test Result..... **Pass**

Date of Test: Apr. 01, 2026 – Apr. 23, 2026

Prepared by: Kevin Pan  
 Project Engineer

Reviewed by: Silver Wan  
 Project Supervisor

Approved by: Jason Zhou  
 Technical Director

The results shown in this test report refer only to the sample(s) tested unless otherwise stated and the sample(s) are retained for 15 days only. The document is issued by Shenzhen HUAKE Testing Technology Co., Ltd., this document cannot be reproduced except in full with our prior written permission.

**Table of Contents**

	<b>Page</b>
<b>1 . TEST SUMMARY</b>	<b>7</b>
1.1 TEST FACILITY	8
1.2 MEASUREMENT UNCERTAINTY	8
<b>2 . GENERAL INFORMATION</b>	<b>9</b>
2.1 GENERAL DESCRIPTION OF EUT	9
2.2 DESCRIPTION OF TEST MODES	10
2.3 DESCRIPTION OF TEST SETUP	11
2.4 DESCRIPTION TEST PERIPHERAL AND EUT PERIPHERAL	12
2.5 MEASUREMENT INSTRUMENTS LIST	13
<b>3 . EMC EMISSION TEST</b>	<b>15</b>
3.1 CONDUCTED EMISSION MEASUREMENT	15
3.1.1 POWER LINE CONDUCTED EMISSION	15
3.1.2 Telecommunication Ports CONDUCTED EMISSION	15
3.1.3 TEST PROCEDURE	16
3.1.4 TEST SETUP	16
3.1.5 EUT OPERATING CONDITIONS	16
3.1.6 TEST RESULTS	17
3.2 RADIATED EMISSION MEASUREMENT	20
3.2.1 LIMITS OF RADIATED EMISSION MEASUREMENT (30~1000MHz)	20
3.2.2 LIMITS OF RADIATED EMISSION MEASUREMENT(1000~6000MHz)	20
3.2.3 TEST PROCEDURE	20
3.2.4 TEST SETUP	21
3.2.5 EUT OPERATING CONDITIONS	21
3.2.6 TEST RESULTS(30~1000MHz)	22
3.2.7 TEST RESULTS(1000~6000MHz)	24
3.3 HARMONICS CURRENT	26
3.3.1 LIMITS OF HARMONICS CURRENT	26
3.3.2 TEST PROCEDURE	27
3.3.3 EUT OPERATING CONDITIONS	27
3.3.4 TEST SETUP	27
3.3.5 TEST RESULTS	28
3.4 VOLTAGE FLUCTUATION AND FLICKERS	29
3.4.1 LIMITS OF VOLTAGE FLUCTUATION AND FLICKERS	29
3.4.2 TEST PROCEDURE	29
3.4.3 EUT OPERATING CONDITIONS	30



**Table of Contents**

	<b>Page</b>
3.4.4 TEST SETUP	30
3.4.5 TEST RESULTS	31
<b>4 . EMC IMMUNITY TEST</b>	<b>32</b>
4.1 STANDARD COMPLIANCE/SEVERITY LEVEL/CRITERIA	32
4.2 GENERAL PERFORMANCE CRITERIA	33
4.3 GENERAL PERFORMANCE CRITERIA TEST SETUP	33
4.4 ESD TESTING	34
4.4.1 TEST SPECIFICATION	34
4.4.2 TEST PROCEDURE	34
4.4.3 TEST SETUP	35
4.4.4 TEST RESULTS	36
4.5 RS TESTING	37
4.5.1 TEST SPECIFICATION	37
4.5.2 TEST PROCEDURE	37
4.5.3 TEST SETUP	38
4.5.4 TEST RESULTS	39
4.6 EFT/BURST TESTING	40
4.6.1 TEST SPECIFICATION	40
4.6.2 TEST PROCEDURE	40
4.6.3 TEST SETUP	41
4.6.4 TEST RESULTS	42
4.7 SURGE TESTING	43
4.7.1 TEST SPECIFICATION	43
4.7.2 TEST PROCEDURE	43
4.7.3 TEST SETUP	44
4.7.4 TEST RESULTS	45
4.8 INJECTION CURRENT TESTING	46
4.8.1 TEST SPECIFICATION	46
4.8.2 TEST PROCEDURE	46
4.8.3 TEST SETUP	47
4.8.4 TEST RESULTS	48
4.9 POWER FREQUENCY MAGNETIC FIELD TESTING	49
4.9.1 TEST SPECIFICATION	49
4.9.2 TEST PROCEDURE	49
4.9.3 TEST SETUP	50
4.9.4 TEST RESULTS	51
4.10 VOLTAGE INTERRUPTION/DIPS TESTING	52
4.10.1 TEST SPECIFICATION	52
4.10.2 TEST PROCEDURE	52

The results shown in this test report refer only to the sample(s) tested unless otherwise stated and the sample(s) are retained for 15 days only. The document is issued by Shenzhen HUAK Testing Technology Co., Ltd., this document cannot be reproduced except in full with our prior written permission.

	<b>Page</b>
4.10.3 TEST SETUP	52
4.10.4 TEST RESULTS	53
5 . EUT TEST PHOTO	54
ATTACHMENT PHOTOGRAPHS OF EUT	58

**\*\* Issued history\*\***

Revision	Description	Issued Date	Remark
Revision 1.0	Initial Test Report Release	2026/04/23	Jason Zhou

QUALIFICATION

The results shown in this test report refer only to the sample(s) tested unless otherwise stated and the sample(s) are retained for 15 days only. The document is issued by Shenzhen HUAK Testing Technology Co., Ltd., this document cannot be reproduced except in full with our prior written permission.



**1. TEST SUMMARY**

Test procedures according to the technical standards:

<b>EMC Emission</b>				
Standard	Test Item	Limit	Judgment	Remark
EN 55032	Conducted Emission (AC port)	Class A	PASS	
	Conducted Emission (Telecommunication port)	Class A	PASS	
	Radiated Emission	Class A	PASS	
EN IEC 61000-3-2	Harmonic Current Emission	Class A	N/A NOTE (2)	
EN 61000-3-3	Voltage Fluctuations & Flicker	-----	PASS	
<b>EMC Immunity</b>				
Section EN 55035	Test Item	Performance Criteria	Judgment	Remark
EN 61000-4-2	Electrostatic Discharge	B	PASS	
EN IEC 61000-4-3	RF electromagnetic field	A	PASS	
EN 61000-4-4	Fast transients	B	PASS	
EN 61000-4-5	Surges	B	PASS	
EN IEC 61000-4-6	Injected Current	A	PASS	
EN 61000-4-8	Power Frequency Magnetic Field	A	N/A	
EN IEC 61000-4-11	Volt. Interruptions Volt. Dips	B / C / C NOTE (3)	PASS	

**NOTE:**

- (1) "N/A" denotes test is not applicable in this Test Report
- (2) The power consumption of EUT is less than 75W and no Limits apply.
- (3) Voltage dip: 100% reduction – Performance Criteria **B**  
Voltage dip: 30% reduction – Performance Criteria **C**  
Voltage Interruption: 100% Interruption – Performance Criteria **C**
- (4) For client's request and manual description, the test will not be executed.
- (5) Equipment meeting Class A requirements may not offer adequate protection to broadcast services within a residential environment.

### 1.1 TEST FACILITY

Shenzhen HUAK Testing Technology Co., Ltd.  
 Address: 1-2/F., Building B2, Junfeng Zhongcheng Zhizao Innovation Park, Heping, Fuhai Street, Bao'an District, Shenzhen, Guangdong, China

### 1.2 MEASUREMENT UNCERTAINTY

The reported uncertainty of measurement  $y \pm U$ , where expanded uncertainty  $U$  is based on a standard uncertainty multiplied by a coverage factor of  $k=2$ , providing a level of confidence of approximately **95 %**.

#### A. Conducted Measurement :

Measurement Frequency Range	Uncertainty	NOTE
150kHz ~ 30MHz	$\pm 2.22\text{dB}$	

#### B. Radiated Measurement :

Measurement Frequency Range	Uncertainty	NOTE
30 ~ 1000MHz	$\pm 3.60\text{dB}$	
1 ~ 6GHz	$\pm 3.86\text{dB}$	



## 2. GENERAL INFORMATION

### 2.1 GENERAL DESCRIPTION OF EUT

Product Name	CM5 AI CAMERA	
Product Model	ED-AIC3100	
Series Model	N/A	
Model Difference	N/A	
Product Description	The EUT is a CM5 AI CAMERA.	
	Operating frequency:	N/A
	Connecting I/O port:	N/A
Power Source	DC Voltage	
Power Rating	DC 24V From Adapter with AC 100-240V, 50/60Hz	

The results shown in this test report refer only to the sample(s) tested unless otherwise stated and the sample(s) are retained for 15 days only. The document is issued by Shenzhen HUAK Testing Technology Co., Ltd., this document cannot be reproduced except in full with our prior written permission.



## 2.2 DESCRIPTION OF TEST MODES

To investigate the maximum EMI emission characteristics generates from EUT, the test system was pre-scanning tested base on the consideration of following EUT operation mode or test configuration mode which possible have effect on EMI emission level. Each of these EUT operation mode(s) or test configuration mode(s) mentioned above was evaluated respectively.

Pretest Mode	Description
Mode 1	Working

For Conducted Test	
Final Test Mode	Description
Mode 1	Working

For Radiated Test	
Final Test Mode	Description
Mode 1	Working

For EMS Test	
Final Test Mode	Description
Mode 1	Working



### 2.3 DESCRIPTION OF TEST SETUP

Mode 1:

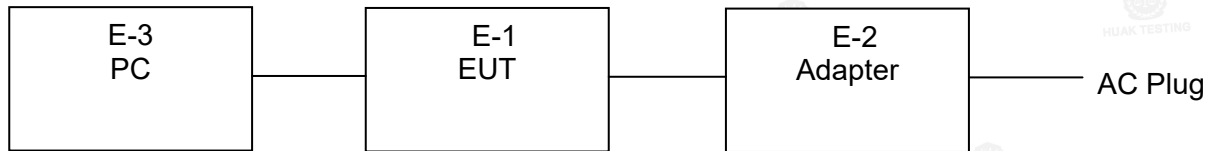



### 2.4 DESCRIPTION TEST PERIPHERAL AND EUT PERIPHERAL

The EUT has been tested as an independent unit together with other necessary accessories or support units. The following support units or accessories were used to form a representative test configuration during the tests.

Item	Equipment	Trade Mark	Model/Type No.	Series No.	Note
E-1	CM5 AI CAMERA	EDATEC	ED-AIC3100	N/A	EUT
E-2	Adapter	N/A	GSM60A24	N/A	
E-3	PC	Lenovo	ThinkPad E14	N/A	

Item	Shielded Type	Ferrite Core	Length	Note

**Note:**

- (1) The support equipment was authorized by Declaration of Confirmation.
- (2) For detachable type I/O cable should be specified the length in cm in 『Length』 column.
- (3) “YES” is means “shielded” “with core”; “NO” is means “unshielded” “without core”.



2.5 MEASUREMENT INSTRUMENTS LIST

2.5.1 CONDUCTED TEST SITE

Item	Test Equipment	Manufacturer	Type No.	Serial No.	Calibration Date	Cal. Due
1	LISN	R&S	ENV216	HKE-002	2026.02.11	2027.02.10
2	LISN	R&S	ENV216	HKE-059	2026.02.04	2027.02.03
3	EMI Test Receiver	R&S	ESR-7	HKE-005	2026.02.06	2027.02.05
4	ISN	ETC	08-06-BAC-0 22-02	HKE-062	2026.02.06	2027.02.05
5	Conducted test software	Tonscend	JS32-CE 2.5.0.6	HKE-081	/	/

2.5.2 RADIATED TEST SITE

Item	Test Equipment	Manufacturer	Type No.	Serial No.	Calibration Date	Cal. Due
1	Broadband antenna	Schwarzbeck	VULB 9163	HKE-012	2026.02.06	2028.02.05
2	Horn antenna	Schwarzbeck	9120D	HKE-013	2026.02.06	2028.02.05
3	EMI Test Receiver	R&S	ESR-7	HKE-010	2026.02.06	2027.02.05
4	Spectrum Analyzer	Agilent	N9020A	HKE-048	2026.02.06	2027.02.05
5	Amplifier	Schwarzbeck	EMC051845 SE	HKE-006	2026.02.06	2027.02.05
6	Amplifier	Agilent	83051A	HKE-016	2026.02.04	2027.02.03
7	Radiated test software	Tonscend	JS32-RE 5.0.0	HKE-082	/	/

2.5.3 HARMONICS AND FILCK

Item	Test Equipment	Manufacturer	Type No.	Serial No.	Calibration Date	Cal. Due
1	Harmonic flicker tester	emtest	DPA 500N	HKE-037	2026.02.06	2027.02.05

2.5.4 ESD

Item	Test Equipment	Manufacturer	Type No.	Serial No.	Calibration Date	Cal. Due
1	ESD device	TESEQ	NSG437	HKE-023	2026.02.03	2027.02.02



**2.5.5 RS**

Item	Test Equipment	Manufacturer	Type No.	Serial No.	Calibration Date	Cal. Due
1	Power amplifier	micotop	MPA-80-1000-250	HKE-142	2026.02.11	2027.02.10
2	Power amplifier	micotop	MPA-1000-6000-100	HKE-143	2026.02.06	2027.02.05
3	Power Meter	KEYSIGHT	E4419B	HKE-144	2026.02.06	2027.02.05
4	Vector signal generator	KEYSIGHT	N5182B	HKE-124	2026.02.04	2027.02.03
5	Field strength probe	NARDA	EP601	HKE-146	2026.02.06	2027.02.05
6	High gain antenna	Schwarzbeck	STPL9129	HKE-147	/	/
7	RS test software	Tonscend	JS35-RS 5.0.0	HKE-186	/	/

**2.5.6 SURGE, EFT/BURST, VOLTAGE INTERRUPTION/DIPS**

Item	Test Equipment	Manufacturer	Type No.	Serial No.	Calibration Date	Cal. Due
1	Full-featured immunity tester	TESEQ	NSG3060	HKE-017	2026.02.04	2027.02.03
2	Pulse coupling clamp	TESEQ	CDN 8014	HKE-024	2026.02.04	2027.02.03

**2.5.7 INJECTION CURRENT**

Item	Test Equipment	Manufacturer	Type No.	Serial No.	Calibration Date	Cal. Due
1	Magnetic clamp	TESEQ	EML-20	HKE-114	2026.02.04	2027.02.03
2	Integrated Conduction Sensitivity Test System	FRANKONIA	CCIT-10	HKE-033	2026.02.04	2027.02.03
3	Coupling decoupling network	TESEQ	CDM316	HKE-032	2026.02.04	2027.02.03

**2.5.8 MF**

Item	Test Equipment	Manufacturer	Type No.	Serial No.	Calibration Date	Cal. Due
1	Power frequency induction coil	LIONCEL	PMF-801C-C	HKE-049	2026.02.06	2027.02.05

The results shown in this test report refer only to the sample(s) tested unless otherwise stated and the sample(s) are retained for 15 days only. The document is issued by Shenzhen HUAK Testing Technology Co., Ltd., this document cannot be reproduced except in full with our prior written permission.



### 3. EMC EMISSION TEST

#### 3.1 CONDUCTED EMISSION MEASUREMENT

##### 3.1.1 POWER LINE CONDUCTED EMISSION (Frequency Range 150kHz~30MHz)

FREQUENCY (MHz)	Class A (dBuV)		Class B (dBuV)	
	Quasi-peak	Average	Quasi-peak	Average
0.15 ~ 0.5	79.00	66.00	66 - 56 *	56 - 46 *
0.50 ~ 5.0	73.00	60.00	56.00	46.00
5.0 ~ 30.0	73.00	60.00	60.00	50.00

Note:

- (1) The tighter limit applies at the band edges.
- (2) The limit of " \* " marked band means the limitation decreases linearly with the logarithm of the frequency in the range.

##### 3.1.2 Telecommunication Ports CONDUCTED (Frequency Range 150kHz~30MHz) EMISSION

FREQUENCY (MHz)	Class A (dBuV)		Class B (dBuV)	
	Quasi-peak	Average	Quasi-peak	Average
0.15 ~ 0.5	97 ~ 87	84 ~ 74	84 ~ 74	74 ~ 64
0.50 ~ 30.0	87.00	74.00	74.00	64.00

Note:

- (1) The tighter limit applies at the band edges.
- (2) The limit of " \* " marked band means the limitation decreases linearly with the logarithm of the frequency in the range.

The following table is the setting of the receiver

Receiver Parameters	Setting
Attenuation	10 dB
Start Frequency	0.15 MHz
Stop Frequency	30 MHz
IF Bandwidth	9 kHz



3.1.3 TEST PROCEDURE

- a. The EUT was placed 0.8 meters from the horizontal ground plane with EUT being connected to the power mains through a line impedance stabilization network (LISN). All other support equipments powered from additional LISN(s). The LISN provide 50 Ohm/ 50uH of coupling impedance for the measuring instrument.
- b. Interconnecting cables that hang closer than 40 cm to the ground plane shall be folded back and forth in the center forming a bundle 30 to 40 cm long.
- c. I/O cables that are not connected to a peripheral shall be bundled in the center. The end of the cable may be terminated, if required, using the correct terminating impedance. The overall length shall not exceed 1 m.
- d. LISN at least 80 cm from nearest part of EUT chassis.
- e. For the actual test configuration, please refer to the related Item –EUT Test Photos.

3.1.4 TEST SETUP

AC Port

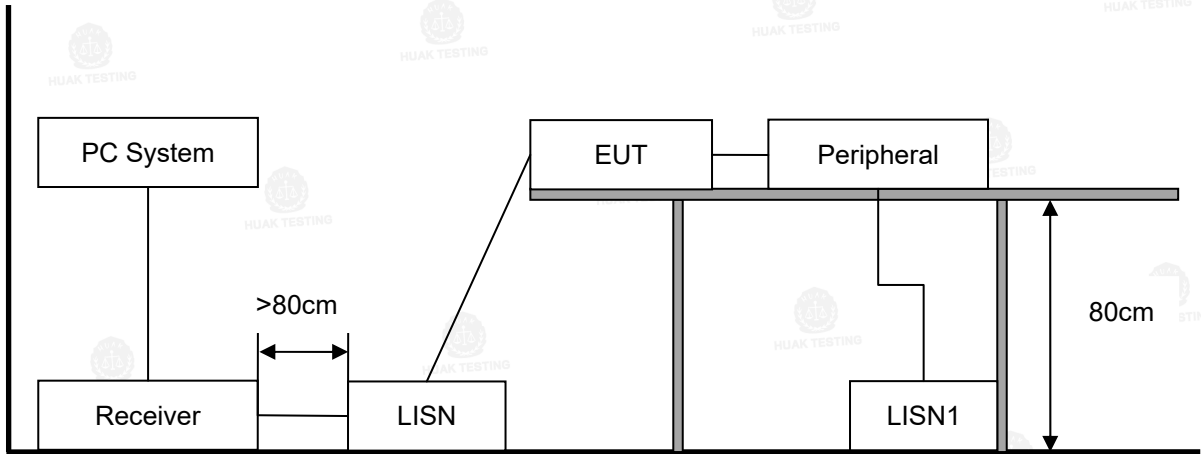

Telecommunication port

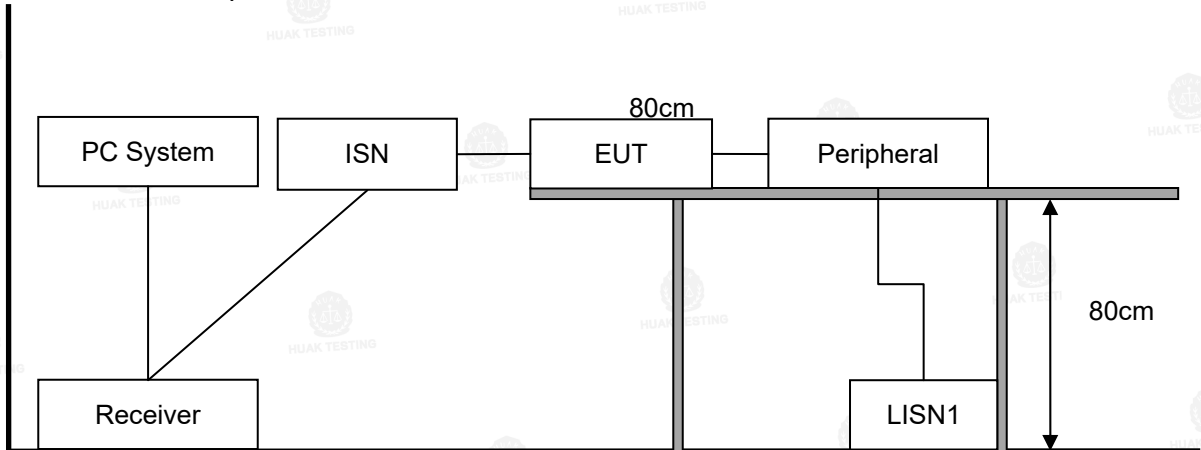

3.1.5 EUT OPERATING CONDITIONS

The EUT tested system was configured as the statements of 2.3 Unless otherwise a special operating condition is specified in the follows during the testing.



3.1.6 TEST RESULTS

EUT :	CM5 AI CAMERA	Model Name. :	ED-AIC3100
Temperature :	24.1 °C	Relative Humidity :	55%
Pressure :	1010hPa	Test Date :	2026-04-08
Test Mode :	Mode 1	Phase :	L
Test Voltage :	DC 24V From Adapter		

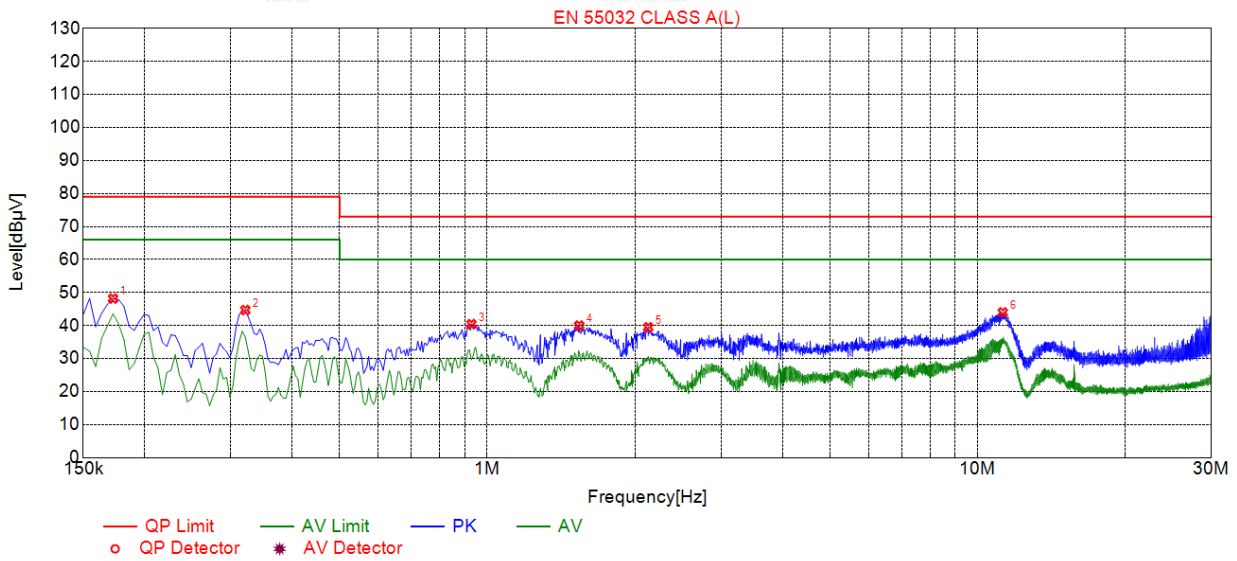

Suspected List								
NO.	Freq. [MHz]	Level [dBµV]	Factor [dB]	Limit [dBµV]	Margin [dB]	Reading [dBµV]	Detector	Type
1	0.1725	48.18	19.81	79.00	30.82	28.37	PK	L
2	0.3210	44.68	19.79	79.00	34.32	24.89	PK	L
3	0.9285	40.41	19.89	73.00	32.59	20.52	PK	L
4	1.5405	39.99	19.98	73.00	33.01	20.01	PK	L
5	2.1300	39.46	20.08	73.00	33.54	19.38	PK	L
6	11.2605	43.98	21.44	73.00	29.02	22.54	PK	L

Remark: Margin = Limit – Level  
Correction factor = Cable lose + LISN insertion loss  
Level=Test receiver reading + correction factor



EUT :	CM5 AI CAMERA	Model Name. :	ED-AIC3100
Temperature :	24.1 °C	Relative Humidity :	55%
Pressure :	1010hPa	Test Date :	2026-04-08
Test Mode :	Mode 1	Phase :	N
Test Voltage :	DC 24V From Adapter		

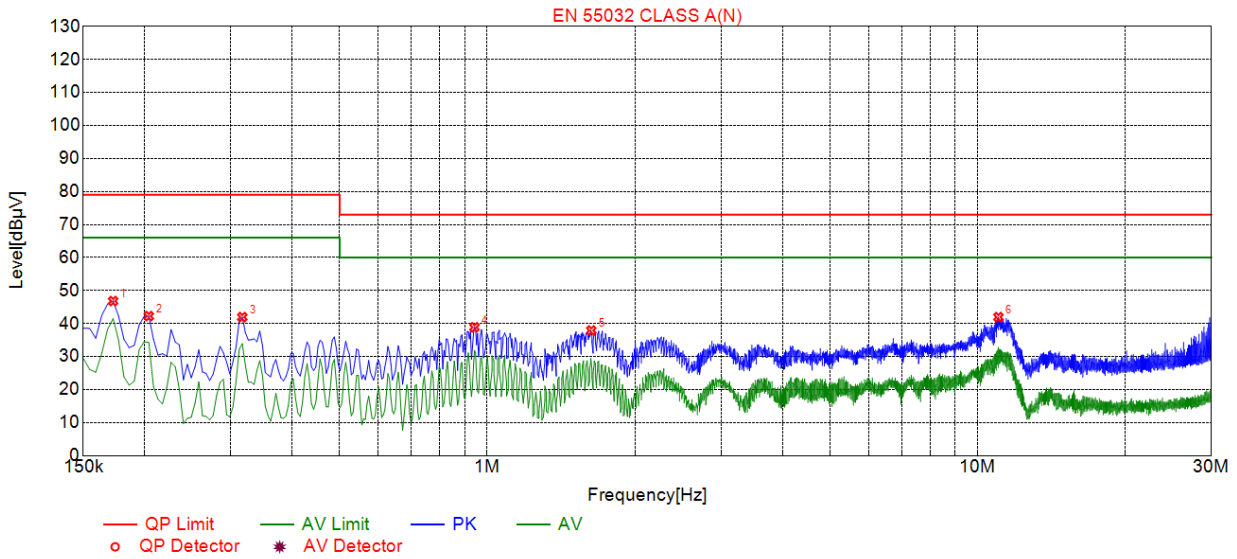

Suspected List								
NO.	Freq. [MHz]	Level [dBµV]	Factor [dB]	Limit [dBµV]	Margin [dB]	Reading [dBµV]	Detector	Type
1	0.1725	48.82	19.86	79.00	32.18	26.96	PK	N
2	0.2040	42.26	19.75	79.00	36.74	22.51	PK	N
3	0.3165	41.97	19.83	79.00	37.03	22.14	PK	N
4	0.9420	38.87	19.97	73.00	34.13	18.90	PK	N
5	1.6305	37.92	20.10	73.00	35.08	17.82	PK	N
6	11.0355	41.95	21.22	73.00	31.05	20.73	PK	N

Remark: Margin = Limit – Level  
Correction factor = Cable lose + LISN insertion loss  
Level=Test receiver reading + correction factor



EUT :	CM5 AI CAMERA	Model Name. :	ED-AIC3100
Temperature :	24.1 °C	Relative Humidity :	55%
Pressure :	1010hPa	Test Date :	2026-04-08
Test Mode :	Mode 1	Phase :	ISN
Test Voltage :	DC 24V From Adapter		

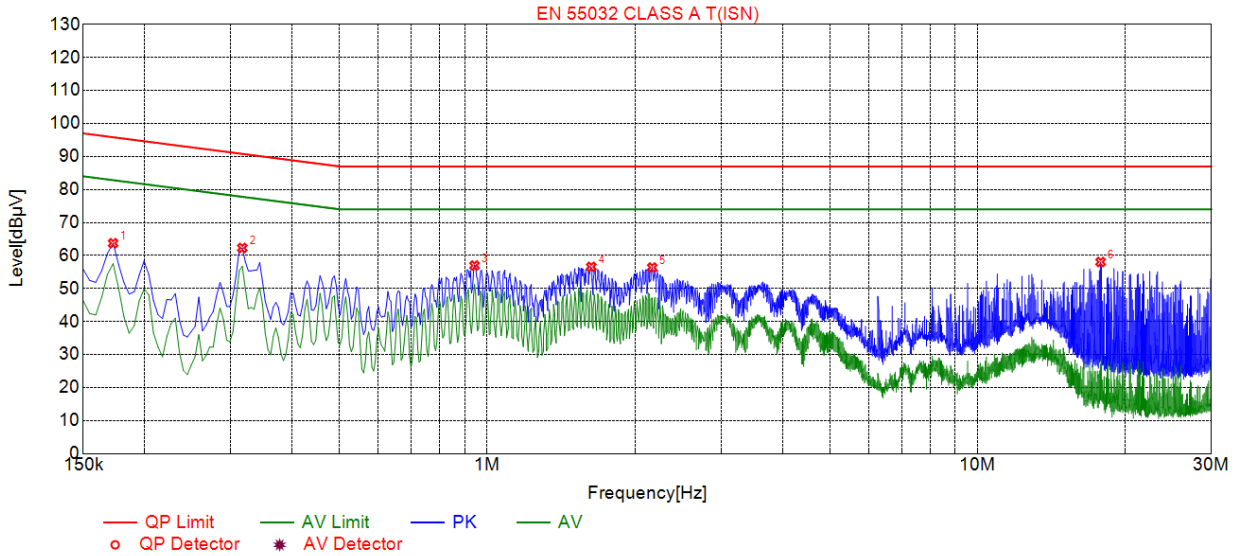

Suspected List								
NO.	Freq. [MHz]	Level [dBµV]	Factor [dB]	Limit [dBµV]	Margin [dB]	Reading [dBµV]	Detector	Type
1	0.1725	63.73	19.88	95.91	32.18	43.85	PK	ISN
2	0.3165	62.30	19.87	90.85	28.55	42.43	PK	ISN
3	0.9420	56.97	19.86	87.00	30.03	37.11	PK	ISN
4	1.6305	56.57	19.87	87.00	30.43	36.70	PK	ISN
5	2.1705	56.36	19.87	87.00	30.64	36.49	PK	ISN
6	17.8305	58.05	19.97	87.00	28.95	38.08	PK	ISN

Remark: Margin = Limit – Level

Correction factor = Cable lose + ISN insertion loss

Level=Test receiver reading + correction factor



### 3.2 RADIATED EMISSION MEASUREMENT

#### 3.2.1 LIMITS OF RADIATED EMISSION MEASUREMENT (30~1000MHz)

FREQUENCY (MHz)	Class A		Class B	
	At 10m	At 3m	At 10m	At 3m
	dBuV/m	dBuV/m	dBuV/m	dBuV/m
30 ~ 230	40	50	30	40
230 ~ 1000	47	57	37	47

#### 3.2.2 LIMITS OF RADIATED EMISSION MEASUREMENT(1000~6000MHz)

FREQUENCY (MHz)	Class A (at 3m) dBuV/m		Class B (at 3m) dBuV/m	
	Peak	Avg	Peak	Avg
1000 ~ 6000	80	60	74	54

Notes:

- (1) The tighter limit applies at the band edges.

#### 3.2.3 TEST PROCEDURE

- The measured distance is 3m.
- The EUT was placed on the top of a rotating table 0.8 meters above the ground at a 3 meter open area test site. The table was rotated 360 degrees to determine the position of the highest radiation.
- The height of the equipment or of the substitution antenna shall be 0.8 m; the height of the test antenna shall vary between 1 m to 4 m. Both horizontal and vertical polarizations of the antenna are set to make the measurement.
- The initial step in collecting conducted emission data is a spectrum analyzer peak detector mode pre-scanning the measurement frequency range. Significant peaks are then marked and then Quasi Peak detector mode re-measured, above 1G Average detector mode will be instead.
- If the Peak Mode measured value compliance with and lower than Quasi Peak Mode Limit, the EUT shall be deemed to meet QP(AV) Limits and then no additional QP Mode measurement performed.
- For the actual test configuration, please refer to the related Item –EUT Test Photos.



### 3.2.4 TEST SETUP

#### (A) Radiated Emission Test Set-Up Frequency(30~1000MHz)

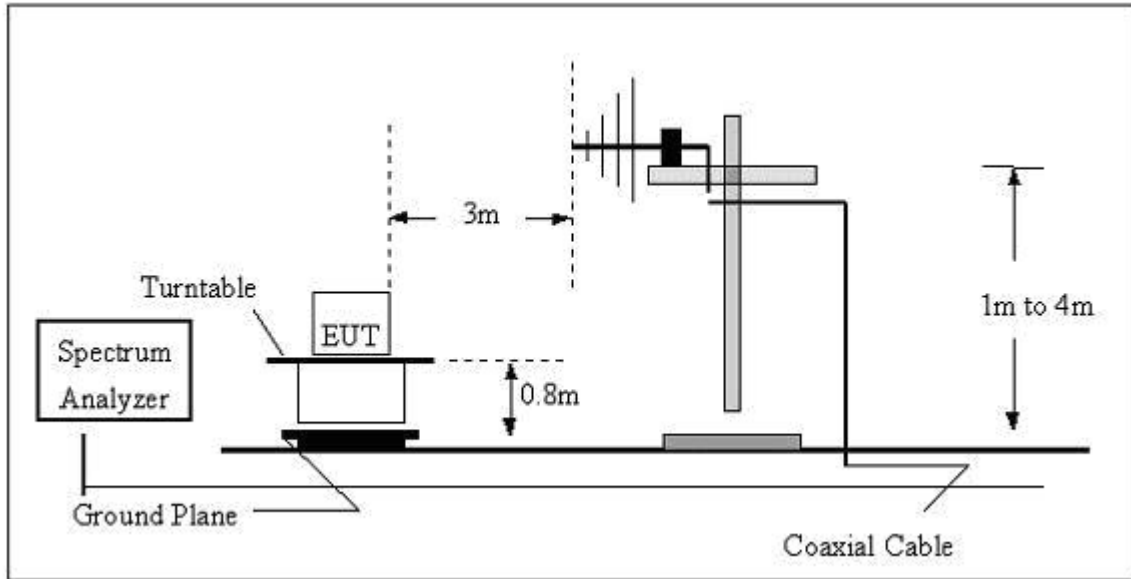

#### (B) Radiated Emission Test Set-Up Frequency(1000~6000MHz)

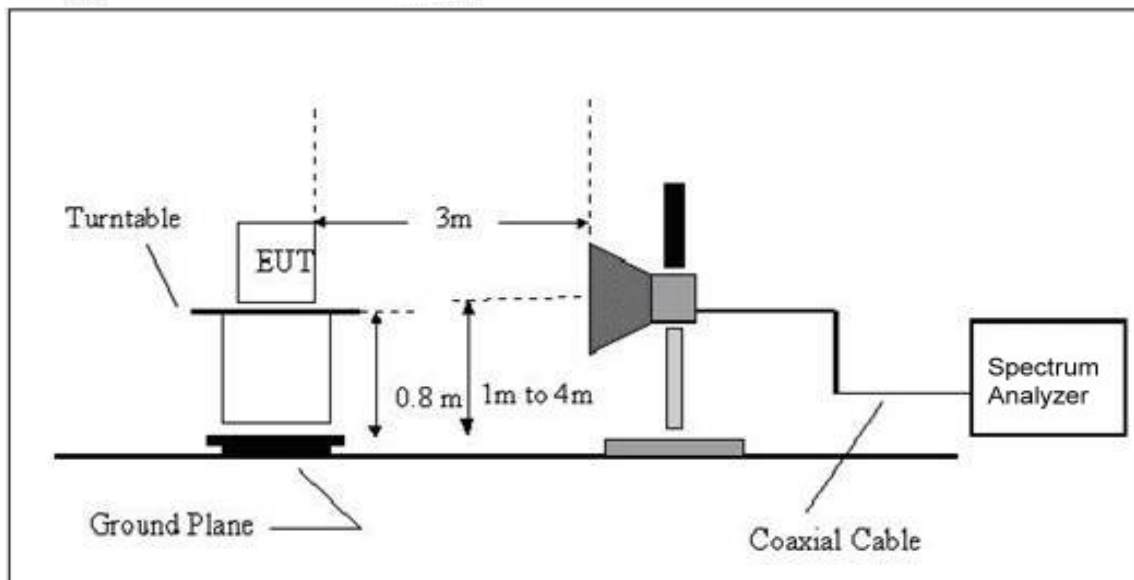

### 3.2.5 EUT OPERATING CONDITIONS

The EUT tested system was configured as the statements of 2.3 Unless otherwise a special operating condition is specified in the follows during the testing.



3.2.6 TEST RESULTS(30~1000MHz)

EUT :	CM5 AI CAMERA	Model Name :	ED-AIC3100
Temperature :	24.2 °C	Relative Humidity :	52%
Pressure :	1010 hPa	Test Date :	2026-04-08
Test Mode :	Mode 1	Polarization :	Horizontal
Test Power :	DC 24V From Adapter		

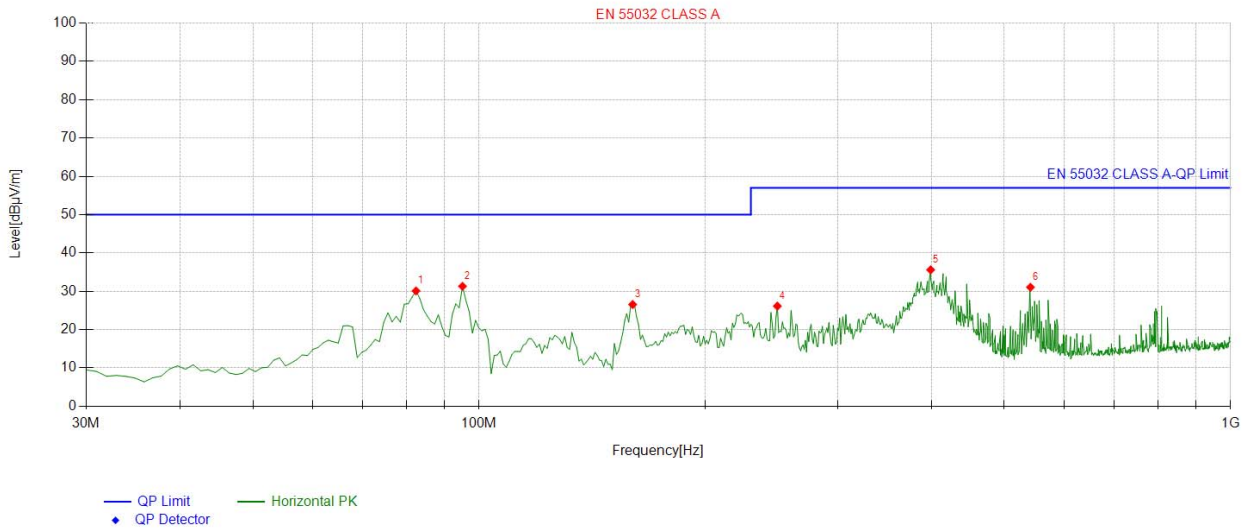

Suspected List									
NO.	Freq. [MHz]	Factor [dB]	Reading [dBµV/m]	Level [dBµV/m]	Limit [dBµV/m]	Margin [dB]	Height [cm]	Angle [°]	Polarity
1	82.432432	-22.84	52.94	30.10	50.00	19.90	100	186	Horizontal
2	95.055055	-22.27	53.58	31.31	50.00	18.69	100	11	Horizontal
3	160.11011	-19.28	45.83	26.55	50.00	23.45	100	35	Horizontal
4	249.43943	-20.91	47.05	26.14	57.00	30.86	100	203	Horizontal
5	398.96896	-18.36	53.95	35.59	57.00	21.41	100	260	Horizontal
6	541.70170	-16.52	47.57	31.05	57.00	25.95	100	72	Horizontal

Final Data List

Remark: Factor = Cable loss + Antenna factor – Pre-amplifier; Level = Reading + Factor; Margin = Limit – Level;



EUT :	CM5 AI CAMERA	Model Name :	ED-AIC3100
Temperature :	24.2 °C	Relative Humidity :	52%
Pressure :	1010 hPa	Test Date :	2026-04-08
Test Mode :	Mode 1	Polarization :	Vertical
Test Power :	DC 24V From Adapter		

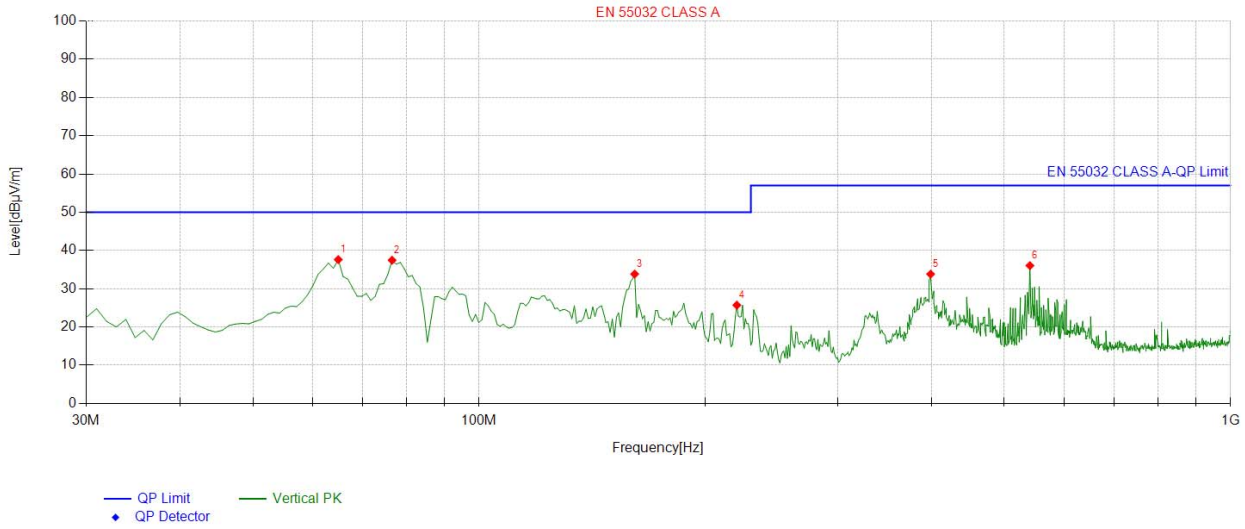

Suspected List									
NO.	Freq. [MHz]	Factor [dB]	Reading [dBµV/m]	Level [dBµV/m]	Limit [dBµV/m]	Margin [dB]	Height [cm]	Angle [°]	Polarity
1	64.954955	-20.24	57.86	37.62	50.00	12.38	100	137	Vertical
2	76.606607	-22.54	59.99	37.45	50.00	12.55	100	157	Vertical
3	161.08108	-19.28	53.11	33.83	50.00	16.17	100	266	Vertical
4	220.31031	-21.80	47.50	25.70	50.00	24.30	100	190	Vertical
5	398.96896	-18.36	52.18	33.82	57.00	23.18	100	142	Vertical
6	540.73073	-16.54	52.59	36.05	57.00	20.95	100	39	Vertical

Final Data List

Remark: Factor = Cable loss + Antenna factor – Pre-amplifier; Level = Reading + Factor; Margin = Limit – Level;

The results shown in this test report refer only to the sample(s) tested unless otherwise stated and the sample(s) are retained for 15 days only. The document is issued by Shenzhen HUAK Testing Technology Co., Ltd., this document cannot be reproduced except in full with our prior written permission.

3.2.7 TEST RESULTS(1000~6000MHz)

EUT :	CM5 AI CAMERA	Model Name :	ED-AIC3100
Temperature :	24.2 °C	Relative Humidity :	52%
Pressure :	1010 hPa	Test Date :	2026-04-08
Test Mode :	Mode 1	Polarization :	Horizontal
Test Power :	DC 24V From Adapter		

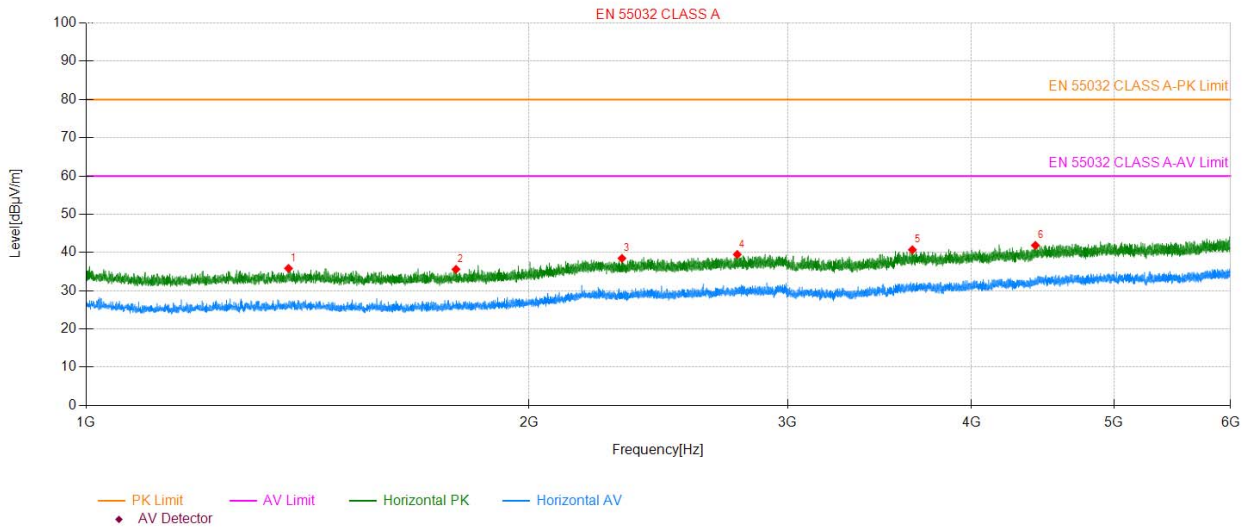

Suspected List									
NO.	Freq. [MHz]	Factor [dB]	Reading [dBµV/m]	Level [dBµV/m]	Limit [dBµV/m]	Margin [dB]	Height [cm]	Angle [°]	Polarity
1	1372.8372	-18.13	53.96	35.83	80.00	44.17	100	270	Horizontal
2	1784.2784	-18.00	53.60	35.60	80.00	44.40	100	60	Horizontal
3	2313.9313	-14.92	53.38	38.46	80.00	41.54	100	80	Horizontal
4	2771.7771	-13.72	53.19	39.47	80.00	40.53	100	150	Horizontal
5	3646.2646	-12.40	53.10	40.70	80.00	39.30	100	60	Horizontal
6	4420.3420	-10.76	52.62	41.86	80.00	38.14	100	210	Horizontal

Remark: Factor = Cable loss + Antenna factor – Preamplifier; Level = Reading + Factor; Margin = Limit – Level;



EUT :	CM5 AI CAMERA	Model Name :	ED-AIC3100
Temperature :	24.2 °C	Relative Humidity :	52%
Pressure :	1010 hPa	Test Date :	2026-04-08
Test Mode :	Mode 1	Polarization :	Vertical
Test Power :	DC 24V From Adapter		

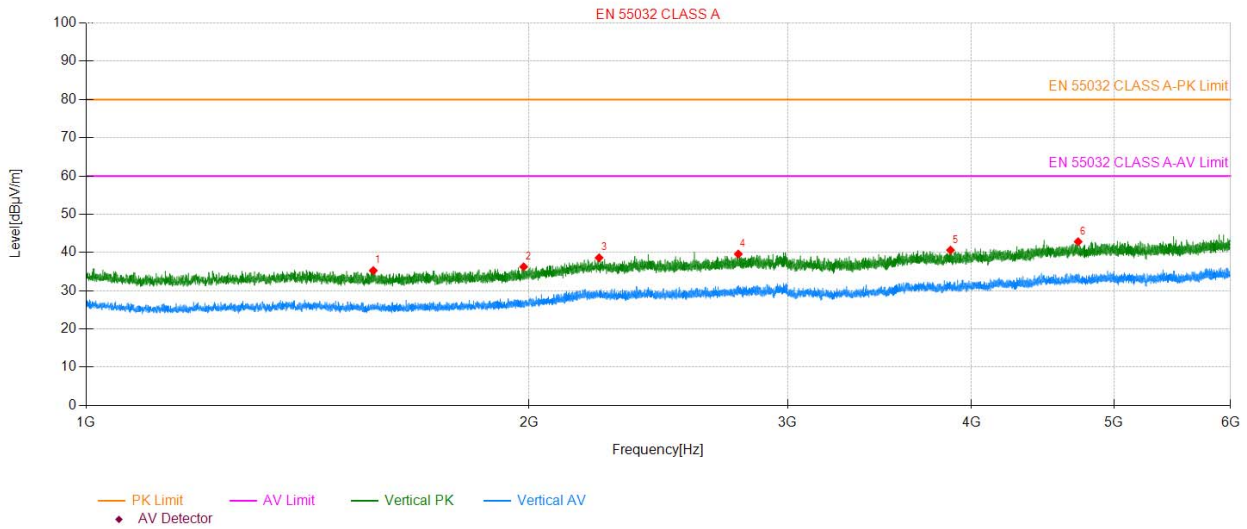

Suspected List									
NO.	Freq. [MHz]	Factor [dB]	Reading [dBµV/m]	Level [dBµV/m]	Limit [dBµV/m]	Margin [dB]	Height [cm]	Angle [°]	Polarity
1	1567.6567	-18.57	53.84	35.27	80.00	44.73	100	20	Vertical
2	1983.8983	-17.02	53.27	36.25	80.00	43.75	100	60	Vertical
3	2232.5232	-14.74	53.35	38.61	80.00	41.39	100	170	Vertical
4	2776.3776	-13.70	53.29	39.59	80.00	40.41	100	70	Vertical
5	3870.3870	-12.04	52.66	40.62	80.00	39.38	100	170	Vertical
6	4726.3726	-9.61	52.43	42.82	80.00	37.18	100	110	Vertical

Remark: Factor = Cable loss + Antenna factor – Preamplifier; Level = Reading + Factor; Margin = Limit – Level;



3.3 HARMONICS CURRENT

3.3.1 LIMITS OF HARMONICS CURRENT

Table 1 – Limits for Class A equipment

Harmonic order <i>h</i>	Maximum permissible harmonic current A
<b>Odd harmonics</b>	
3	2,30
5	1,14
7	0,77
9	0,40
11	0,33
13	0,21
$15 \leq h \leq 39$	$0,15 \frac{15}{h}$
<b>Even harmonics</b>	
2	1,08
4	0,43
6	0,30
$8 \leq h \leq 40$	$0,23 \frac{8}{h}$

Table 3 – Limits for Class D equipment

Harmonic order <i>h</i>	Maximum permissible harmonic current per watt mA/W	Maximum permissible harmonic current A
3	3,4	2,30
5	1,9	1,14
7	1,0	0,77
9	0,5	0,40
11	0,35	0,33
$13 \leq h \leq 39$ (odd harmonics only)	$\frac{3,85}{h}$	See Table 1

The results shown in this test report refer only to the sample(s) tested unless otherwise stated and the sample(s) are retained for 15 days only. The document is issued by Shenzhen HUAK Testing Technology Co., Ltd., this document cannot be reproduced except in full with our prior written permission.



### 3.3.2 TEST PROCEDURE

a. The EUT was placed on the top of a wooden table 0.8 meters above the ground and operated to produce the maximum harmonic components under normal operating conditions.

b. The classification of EUT is according to section 5 of EN IEC 61000-3-2. The EUT is classified as follows:

Class A: Equipment not specified as belonging to Class B,C or D shall be considered as Class A equipment.

Class B: Portable tools;

Arc welding equipment which is not professional equipment.

Class C: Lighting equipment.

Class D: Equipment having a specified power less than or equal to 600 W of the following types:

Personal computers and personal computer monitors;

Television receivers.

c. The correspondent test program of test instrument to measure the current harmonics emanated from EUT is chosen. The measure time shall be not less than the time necessary for the EUT to be exercised.

### 3.3.3 EUT OPERATING CONDITIONS

The EUT tested system was configured as the statements of 2.3 Unless otherwise a special operating condition is specified in the follows during the testing.

### 3.3.4 TEST SETUP

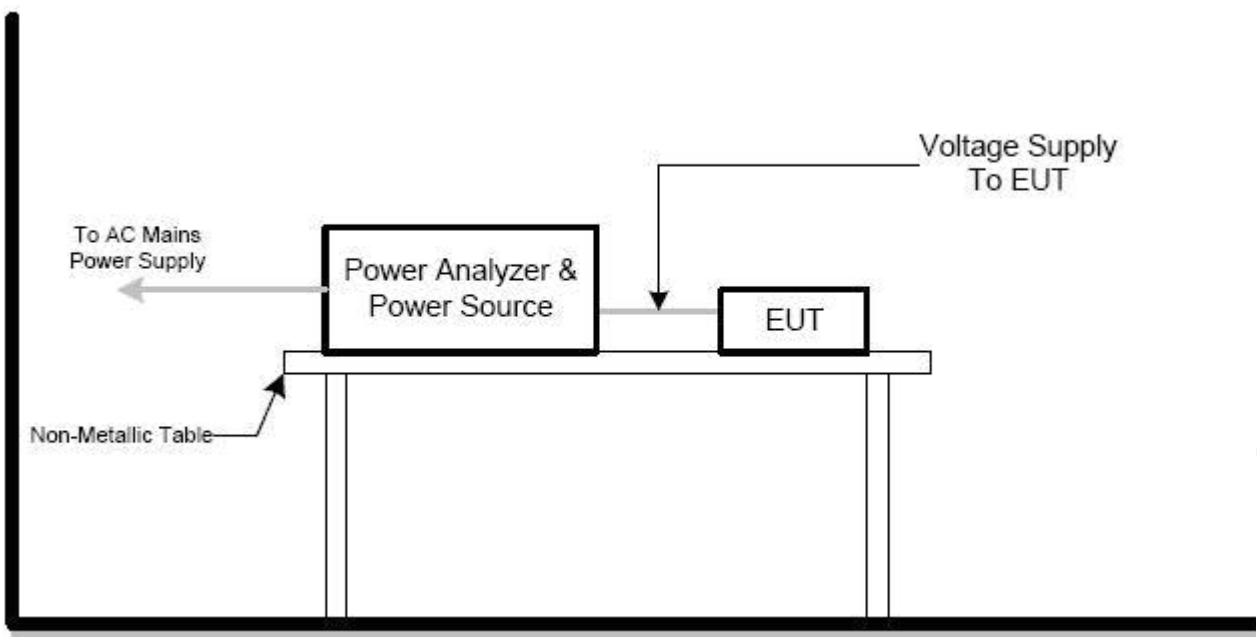

### 3.3.5 TEST RESULTS

EUT :	CM5 AI CAMERA	Model Name :	ED-AIC3100
Temperature :	N/A	Relative Humidity :	N/A
Pressure :	N/A	Test Date :	N/A
Test Mode :	N/A		
Test Power :	N/A		
Note: EUT power is less than 75W, so this test report is not applicable.			



### 3.4 VOLTAGE FLUCTUATION AND FLICKERS

#### 3.4.1 LIMITS OF VOLTAGE FLUCTUATION AND FLICKERS

The limits shall be applicable to voltage fluctuations and flicker at the supply terminals of the equipment under test, measured or calculated according to Clause 4 under test conditions described in Clause 6 and Annex A.

Tests made to prove compliance with the limits are considered to be type tests.

The following limits apply:

the value of  $P_{st}$  shall not be greater than 1.0;

the value of  $P$  shall not be greater than 0.65;

$T_{max}$ , the accumulated time value of  $d(t)$  with a deviation exceeding 3.3 % during a single voltage change at the EUT terminals, shall not exceed 500 ms;

the maximum relative steady-state voltage change,  $d_c$ , shall not exceed 3.3 %;

the maximum relative voltage change  $d_{max}$ , shall not exceed:

a) 4% without additional conditions;

b) 6% for equipment which is:

switched manually, or

switched automatically more frequently than twice per day, and also has either a delayed restart (the delay being not less than a few tens of seconds), or manual restart, after a power supply interruption.

NOTE The cycling frequency is further limited by the  $P$  and  $P$  limits. For example: a  $d_{max}$  of 6 % producing a rectangular voltage change characteristic twice per hour gives a  $P$  of about 0.65.

c) 7% for equipment which is: attended whilst in use (for example: hair dryers, vacuum cleaners, kitchen equipment such as mixers, garden equipment such as lawn mowers, portable tools such as electric drills), or

switched on automatically, or is intended to be switched on manually, no more than twice per day, and also has either a delayed restart (the delay being not less than a few tens of seconds) or manual restart, after a power supply interruption.

In the case of equipment having several separately controlled circuits in accordance with 6.6, limits b) and c) shall apply only if there is delayed or manual restart after a power supply interruption; for all equipment with automatic switching which is energized immediately on restoration of supply after a power supply interruption, limits a) shall apply.

For all equipment with manual switching, limits b) or c) shall apply depending on the rate of switching typical of normal operation.

#### 3.4.2 TEST PROCEDURE

##### a. Harmonic Current Test:

Test was performed according to the procedures specified in Clause 5.0 of IEC555-2 and/or Sub-clause 6.2 of IEC/EN IEC 61000-3-2 depend on which standard adopted for compliance measurement.

##### b. Fluctuation and Flickers Test:

Tests was performed according to the Test Conditions/Assessment of Voltage Fluctuations specified in Clause 5.0/6.0 of IEC555-3 and/or Clause 6.0/4.0 of IEC/EN 61000-3-3 depend on which standard adopted for compliance measurement.

c. All types of harmonic current and/or voltage fluctuation in this report are assessed by direct measurement using flicker-meter.



### 3.4.3 EUT OPERATING CONDITIONS

The EUT tested system was configured as the statements of **2.3** Unless otherwise a special operating condition is specified in the follows during the testing.

### 3.4.4 TEST SETUP

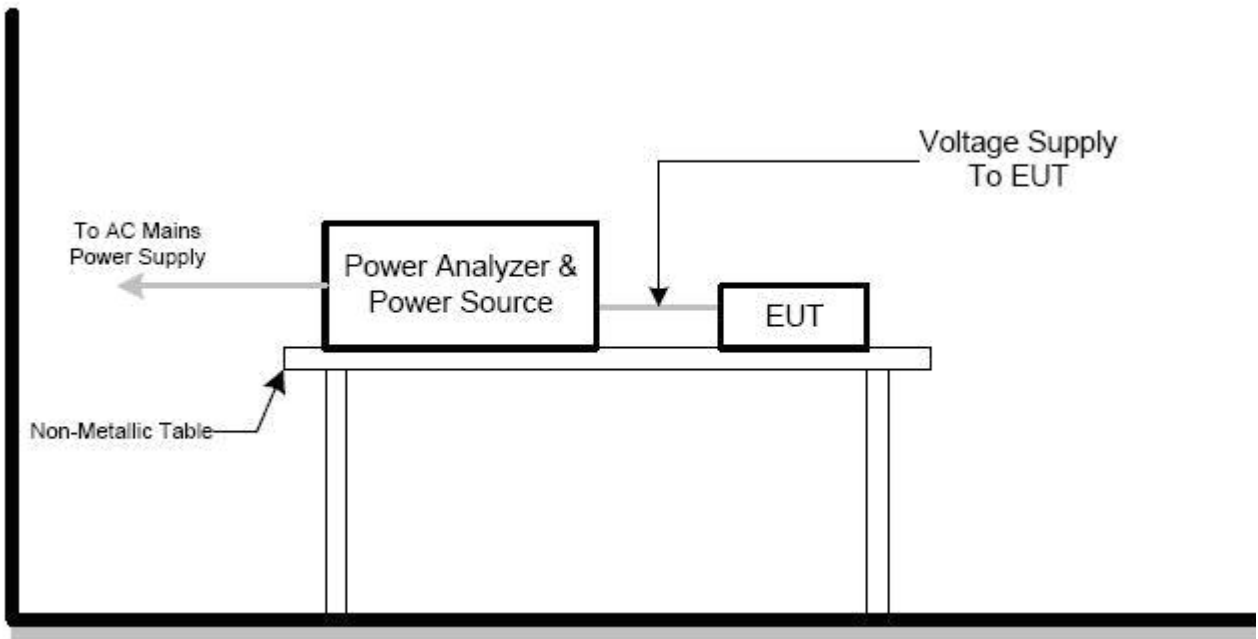



3.4.5 TEST RESULTS

EUT :	CM5 AI CAMERA	Model Name :	ED-AIC3100
Temperature :	24.5 °C	Relative Humidity :	55%
Pressure :	1010 hPa	Test Date :	2026-04-08
Test Mode :	Mode 1		
Test Power :	DC 24V From Adapter		
Test Result:	Pass		

Flicker Measurements					
	P <sub>ft</sub>	Max P <sub>st</sub>	Max D <sub>c</sub>	Max D <sub>max</sub>	Max T <sub>max</sub>
Line 1:	0.012	0.028	0	< 0.2	0
Limits:	0.65	1	3.3	4	0.5
Results:	PASS	PASS	PASS	PASS	PASS



The results shown in this test report refer only to the sample(s) tested unless otherwise stated and the sample(s) are retained for 15 days only. The document is issued by Shenzhen HUAKE Testing Technology Co., Ltd., this document cannot be reproduced except in full with our prior written permission.



**4. EMC IMMUNITY TEST**

**4.1 STANDARD COMPLIANCE/SEVERITY LEVEL/CRITERIA**

Tests Standard No.	TEST SPECIFICATION	Test Mode Test Ports	Perform. Criteria
1. ESD IEC/EN 61000-4-2	8KV air discharge 4KV contact discharge	Direct Mode	B
	4KV HCP discharge 4KV VCP discharge	Indirect Mode	B
2. RS IEC/EN IEC 61000-4-3	80 MHz to 1000 MHz, 1800(±1%)MHz, 2600(±1%)MHz, 3500(±1%)MHz, 5000(±1%)MHz, 1000Hz, 80%, AM modulated	Enclosure	A
3. EFT/Burst IEC/EN 61000-4-4	5/50ns Tr/Th 5kHz Repetition Freq.	Power Supply Port	B
	5/50ns Tr/Th 5kHz Repetition Freq.	CTL/Signal Data Line Port	B
4. Surges IEC/EN 61000-4-5	1.2/50(8/20) Tr/Th us	L-N	B
	1.2/50(8/20) Tr/Th us	L-PE N-PE	B
5 Injected Current IEC/EN IEC 61000-4-6	0.15 MHz to 80 MHz, 1000Hz 80%, AM Modulated 150Ω source impedance	CTL/Signal Port	A
	0.15 MHz to 80 MHz, 1000Hz 80%, AM Modulated 150Ω source impedance	AC Power Port	A
	0.15 MHz to 80 MHz, 1000Hz 80%, AM Modulated 150Ω source impedance	DC Power Port	A
6. Power Frequency Magnetic Field IEC/EN 61000-4-8	50 Hz,	Enclosure	A
7. Volt. Interruptions Volt. Dips IEC/EN IEC 61000-4-11	Voltage dip 100%	AC Power Port	B
	Voltage dip 30%		C
	Interruption 100%		C

The results shown in this test report refer only to the sample(s) tested unless otherwise stated and the sample(s) are retained for 15 days only. The document is issued by Shenzhen HUAK Testing Technology Co., Ltd., this document cannot be reproduced except in full with our prior written permission.



#### 4.2 GENERAL PERFORMANCE CRITERIA

According to **EN 55035** standard, the general performance criteria as following:

<b>Criterion A</b>	The equipment shall continue to operate as intended without operator intervention. No degradation of performance, loss of function or change of operating state is allowed below a performance level specified by the manufacturer when the equipment is used as intended. The performance level may be replaced by a permissible loss of performance. If the minimum performance level or the permissible performance loss is not specified by the manufacturer, then either of these may be derived from the product description and documentation, and by what the user may reasonably expect from the equipment if used as intended.
<b>Criterion B</b>	During the application of the disturbance, degradation of performance is allowed. However, no unintended change of actual operating state or stored data is allowed to persist after the test. After the test, the equipment shall continue to operate as intended without operator intervention; no degradation of performance or loss of function is allowed, below a performance level specified by the manufacturer, when the equipment is used as intended. The performance level may be replaced by a permissible loss of performance. If the minimum performance level (or the permissible performance loss), or recovery time, is not specified by the manufacturer, then either of these may be derived from the product description and documentation, and by what the user may reasonably expect from the equipment if used as intended.
<b>Criterion C</b>	Loss of function is allowed, provided the function is self-recoverable, or can be restored by the operation of the controls by the user in accordance with the manufacturer's instructions. A reboot or re-start operation is allowed. Information stored in non-volatile memory, or protected by a battery backup, shall not be lost.

#### 4.3 GENERAL PERFORMANCE CRITERIA TEST SETUP

The EUT tested system was configured as the statements of **2.3** Unless otherwise a special operating condition is specified in the follows during the testing.



#### 4.4 ESD TESTING

##### 4.4.1 TEST SPECIFICATION

Basic Standard:	IEC/EN 61000-4-2
Discharge Impedance:	330 ohm / 150 pF
Required Performance	B
Discharge Voltage:	Air Discharge : 2kV/4kV/8kV (Direct) Contact Discharge : 2kV/4kV (Direct/Indirect)
Polarity:	Positive & Negative
Number of Discharge:	Air Discharge: min. 20 times at each test point Contact Discharge: min. 200 times in total
Discharge Mode:	Single Discharge
Discharge Period:	1 second minimum

##### 4.4.2 TEST PROCEDURE

The test generator necessary to perform direct and indirect application of discharges to the EUT in the following manner:

- a. Contact discharge was applied to conductive surfaces and coupling planes of the EUT. During the test, it was performed with single discharges. For the single discharge time between successive single discharges was at least 1 second. The EUT shall be exposed to at least 200 discharges, 100 each at negative and positive polarity, at a minimum of four test points. One of the test points shall be subjected to at least 50 indirect discharges to the center of the front edge of the horizontal coupling plane. The remaining three test points shall each receive at least 50 direct contact discharges.

If no direct contact test points are available, then at least 200 indirect discharges shall be applied in the indirect mode. Test shall be performed at a maximum repetition rate of one discharge per second.

**Vertical Coupling Plane (VCP):**

The coupling plane, of dimensions 0.5m x 0.5m, is placed parallel to, and positioned at a distance 0.1m from, the EUT, with the Discharge Electrode touching the coupling plane.

The four faces of the EUT will be performed with electrostatic discharge.

**Horizontal Coupling Plane (HCP):**

The coupling plane is placed under to the EUT. The generator shall be positioned vertically at a distance of 0.1m from the EUT, with the Discharge Electrode touching the coupling plane.

The four faces of the EUT will be performed with electrostatic discharge.

- b. Air discharges at insulation surfaces of the EUT.

It was at least ten single discharges with positive and negative at the same selected point.



### 4.4.3 TEST SETUP

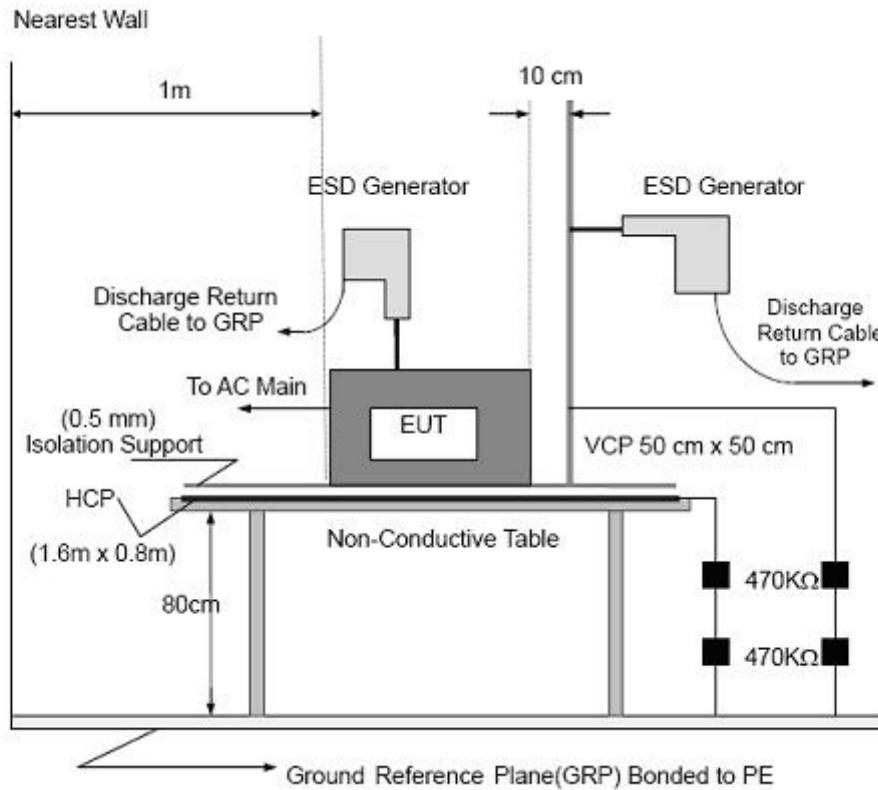

**Note:**

#### TABLE-TOP EQUIPMENT

The configuration consisted of a wooden table 0.8 meters high standing on the Ground Reference Plane. The GRP consisted of a sheet of aluminum at least 0.25mm thick, and 2.5 meters square connected to the protective grounding system. A Horizontal Coupling Plane (1.6m x 0.8m) was placed on the table and attached to the GRP by means of a cable with 940k total impedance. The equipment under test, was installed in a representative system as described in section 7 of IEC /EN 61000-4-2, and its cables were placed on the HCP and isolated by an insulating support of 0.5mm thickness. A distance of 1-meter minimum was provided between the EUT and the walls of the laboratory and any other metallic structure.

#### FLOOR-STANDING EQUIPMENT

The equipment under test was installed in a representative system as described in section 7 of IEC/EN 61000-4-2, and its cables were isolated from the Ground Reference Plane by an insulating support of 0.1-meter thickness. The GRP consisted of a sheet of aluminum that is at least 0.25mm thick, and 2.5meters square connected to the protective grounding system and extended at least 0.5 meters from the EUT on all sides.



4.4.4 TEST RESULTS

EUT :	CM5 AI CAMERA	Model Name :	ED-AIC3100
Temperature :	24.5 °C	Relative Humidity :	55%
Pressure :	1010 hPa	Test Date :	2026-04-08
Test Mode :	Mode 1		
Test Power :	DC 24V From Adapter		

Mode	Air Discharge								Contact Discharge								Criterion	Result
	4		8		10		15		2		4		6		8			
Test level (kV)																		
Test Location	+	-	+	-	+	-	+	-	+	-	+	-	+	-	+	-		
HCP									A	A	A	A						
VCP									A	A	A	A						
Metallic parts									A	A	A	A						
enclosure	A	A	A	A														
slot	A	A	A	A														

Note:

- 1) +/- denotes the Positive/Negative polarity of the output voltage.
- 2) Test condition:  
Direct / Indirect (HCP/VCP) discharges: Minimum 50 times (Positive/Negative) at each point. Air discharges: Minimum 10 times (Positive/Negative) at each point.
- 3) The Indirect (HCP/VCP) discharges description of test point as following:  
1.left side 2.right side 3.front side 4.rear side
- 4) N/A - denotes test is not applicable in this test report



## 4.5 RS TESTING

### 4.5.1 TEST SPECIFICATION

Basic Standard:	IEC/EN IEC 61000-4-3
Required Performance	A
Frequency Range:	80 MHz - 1000 MHz, 1800(±1%)MHz, 2600(±1%)MHz, 3500(±1%)MHz, 5000(±1%)MHz
Field Strength:	3 V/m
Modulation:	1kHz Sine Wave, 80%, AM Modulation
Frequency Step:	1 % of fundamental
Polarity of Antenna:	Horizontal and Vertical
Test Distance:	3 m
Antenna Height:	1.5 m
Dwell Time:	at least 3 seconds

### 4.5.2 TEST PROCEDURE

The EUT and support equipment, which are placed on a table that is 0.8 meter above ground and the testing was performed in a fully-anechoic chamber.

The testing distance from antenna to the EUT was 3 meters.

The other condition as following manner:

- a. The frequency range is swept from 80 MHz - 1000 MHz, 1800(±1%)MHz, 2600(±1%)MHz, 3500(±1%)MHz, 5000(±1%)MHz with the signal 80%amplitude modulated with a 1kHz sine wave. Where the frequency range is swept incrementally. the step size shall not exceed 1 % of the preceding frequency.
- b. The dwell time of the modulated carrier at each frequency shall not be less than the time necessary for the EUT to be exercised and to respond, but shall in no case be less than 0.5 s.
- c. The test was performed with the EUT exposed to both vertically and horizontally polarized fields on each of the four sides.



### 4.5.3 TEST SETUP

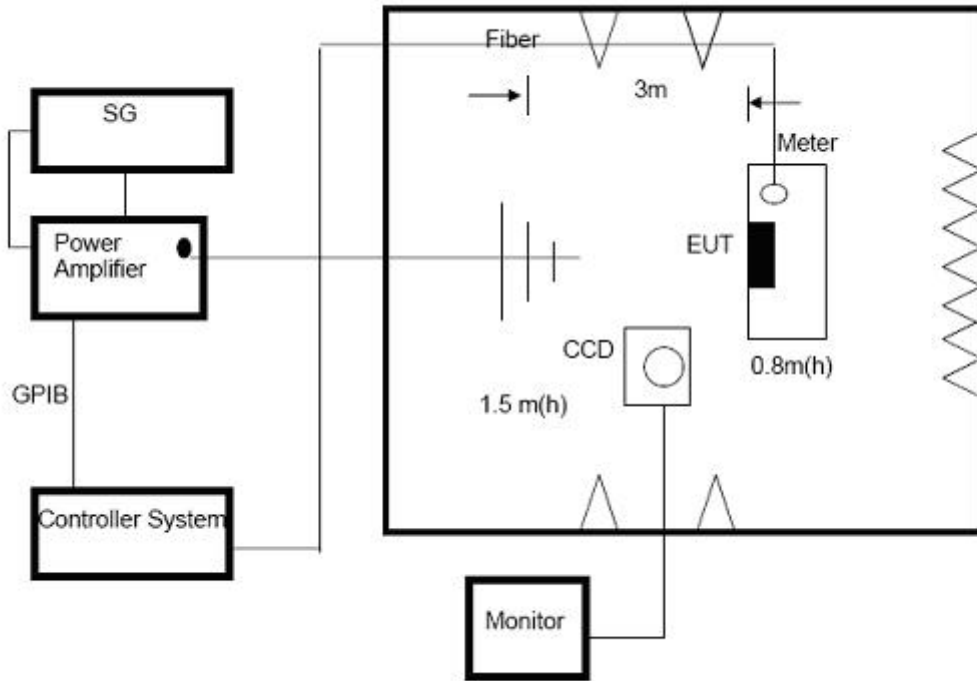

**Note:**

**TABLE-TOP EQUIPMENT**

The EUT installed in a representative system as described in section 7 of IEC/EN IEC 61000-4-3 was placed on a non-conductive table 0.8 meters in height. The system under test was connected to the power and signal wire according to relevant installation instructions.

**FLOOR-STANDING EQUIPMENT**

The EUT installed in a representative system as described in section 7 of IEC/EN IEC 61000-4-3 was placed on a non-conductive wood support 0.1 meters in height. The system under test was connected to the power and signal wire according to relevant installation instructions.



4.5.4 TEST RESULTS

EUT :	CM5 AI CAMERA	Model Name :	ED-AIC3100
Temperature :	24.6 °C	Relative Humidity :	56%
Pressure :	1010 hPa	Test Date :	2026-04-08
Test Mode :	Mode 1		
Test Power :	DC 24V From Adapter		

Frequency Range (MHz)	RF Field Position	R.F. Field Strength	Azimuth	Perform. Criteria	Results	Judgment
80-1000, 1800 (±1%), 2600 (±1%), 3500 (±1%), 5000 (±1%)	H / V	3 V/m (rms) AM Modulated 1000Hz, 80%	Front	<b>A</b>	<b>A</b>	<b>PASS</b>
			Rear			
			Left			
			Right			

Note:

- 1) N/A - denotes test is not applicable in this test report.
- 2) Criteria A: There was no change operated with initial operating during the test.
- 3) Criteria B: The EUT function loss during the test, but self-recoverable after the test.
- 4) Criteria C: The system shut down during the test.



#### 4.6 EFT/BURST TESTING

##### 4.6.1 TEST SPECIFICATION

Basic Standard:	IEC/EN 61000-4-4
Required Performance	B
Test Voltage:	Power Line : 1 kV Signal/Control Line : 0.5 KV
Polarity:	Positive & Negative
Impulse Frequency:	5 kHz
Impulse Wave shape :	5/50 ns
Burst Duration:	15 ms
Burst Period:	300 ms
Test Duration:	Not less than 1 min.

##### 4.6.2 TEST PROCEDURE

The EUT and support equipment, are placed on a table that is 0.8 meter above a metal ground plane measured 1m\*1m min. and 0.25mm aluminum thickness.

The other condition as following manner:

- a. The length of power cord between the coupling device and the EUT should not exceed 1 meter.
- b. Both positive and negative polarity discharges were applied.
- c. The duration time of each test sequential was 1 minute



### 4.6.3 TEST SETUP

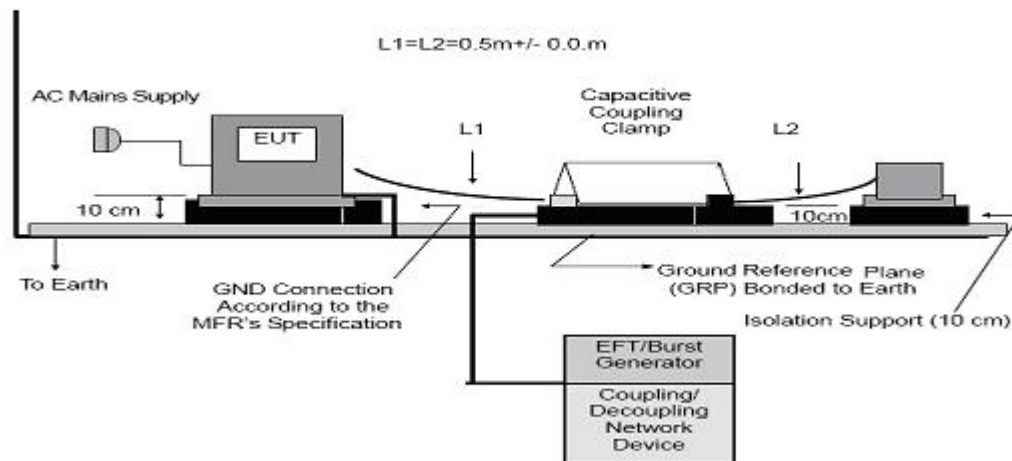
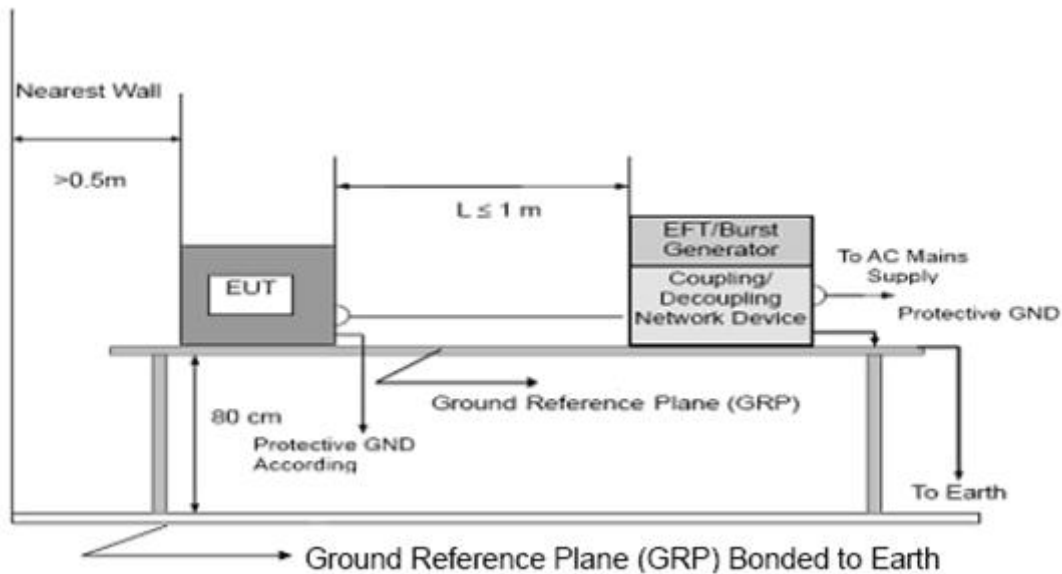

**Note:**

#### TABLE-TOP EQUIPMENT

The configuration consisted of a wooden table (0.8m high) standing on the Ground Reference Plane. The GRP consisted of a sheet of aluminum (at least 0.25mm thick and 2.5m square) connected to the protective grounding system. A minimum distance of 0.5m was provided between the EUT and the walls of the laboratory or any other metallic structure.

#### FLOOR-STANDING EQUIPMENT

The EUT installed in a representative system as described in section 7 of IEC/EN 61000-4-4 and its cables, were isolated from the Ground Reference Plane by an insulating support that is 0.1-meter thick. The GRP consisted of a sheet of aluminum (at least 0.25mm thick and 2.5m square) connected to the protective grounding system.



4.6.4 TEST RESULTS

EUT :	CM5 AI CAMERA	Model Name :	ED-AIC3100
Temperature :	24.5 °C	Relative Humidity :	55%
Pressure :	1010 hPa	Test Date :	2026-04-08
Test Mode :	Mode 1		
Test Power :	DC 24V From Adapter		

Coupling Line	Test level (kV)								Criterion	Result	
	0.5		1		2		4				
	+	-	+	-	+	-	+	-			
AC line	L	A	A	A	A					B	PASS
	N	A	A	A	A						PASS
	PE	A	A	A	A						PASS
	L+N	A	A	A	A						PASS
	L+PE	A	A	A	A						PASS
	N+PE	A	A	A	A						PASS
	L+N+PE	A	A	A	A						PASS
DC Line											
Signal Line	A	A									PASS

Note:

- 1) +/- denotes the Positive/Negative polarity of the output voltage.
- 2) N/A - denotes test is not applicable in this test report
- 3) Criteria A: There was no change operated with initial operating during the test.
- 4) Criteria B: The EUT function loss during the test, but self-recoverable after the test.
- 5) Criteria C: The system shut down during the test.



#### 4.7 SURGE TESTING

##### 4.7.1 TEST SPECIFICATION

Basic Standard:	IEC/EN 61000-4-5
Required Performance	B
Wave-Shape:	Combination Wave 1.2/50 us Open Circuit Voltage 8 /20 us Short Circuit Current
Test Voltage:	Power Line : 0.5 kV, 1 kV, 2 kV
Surge Input/Output:	AC Line
Generator Source:	2 ohm between networks
Impedance:	12 ohm between network and ground
Polarity:	Positive/Negative
Phase Angle:	0/90/180/270°
Pulse Repetition Rate:	1 time / min. (maximum)
Number of Tests:	5 positive and 5 negative at selected points

##### 4.7.2 TEST PROCEDURE

a. For EUT power supply:

The surge is to be applied to the EUT power supply terminals via the capacitive coupling network. Decoupling networks are required in order to avoid possible adverse effects on equipment not under test that may be powered by the same lines, and to provide sufficient decoupling impedance to the surge wave. The power cord between the EUT and the coupling/decoupling networks shall not exceed 2m in length.

b. For test applied to unshielded unsymmetrical operated interconnection lines of EUT:

The surge is applied to the lines via the capacitive coupling. The coupling /decoupling networks shall not influence the specified functional conditions of the EUT. The interconnection line between the EUT and the coupling/decoupling networks shall not exceed 2m in length.

c. For test applied to unshielded symmetrical operated interconnection /telecommunication lines of EUT:

d. The surge is applied to the lines via gas arrestors coupling. Test levels below the ignition point of the coupling arrestor cannot be specified. The interconnection line between the EUT and the coupling/decoupling networks shall not exceed 2m in length.



### 4.7.3 TEST SETUP

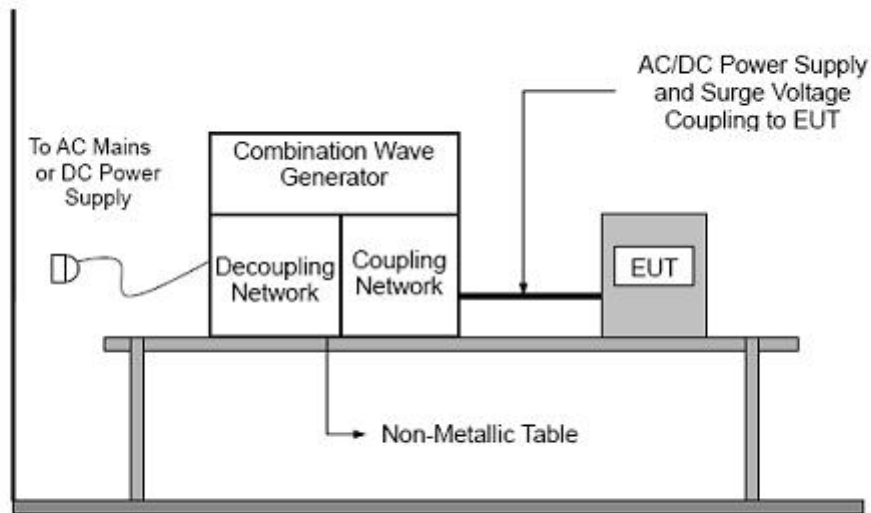



4.7.4 TEST RESULTS

EUT :	CM5 AI CAMERA	Model Name :	ED-AIC3100
Temperature :	24.5 °C	Relative Humidity :	55%
Pressure :	1010 hPa	Test Date :	2026-04-08
Test Mode :	Mode 1		
Test Power :	DC 24V From Adapter		

Coupling Line			Test level								Criterion	Result
			0.5 kV		1 kV		2 kV		4 kV			
			+	-	+	-	+	-	+	-		
AC line	L-N	0°									B	PASS
		90°	A		A							
		180°										
		270°		A		A						
	L-PE	0°										PASS
		90°	A		A		A					
		180°										
		270°		A		A		A				
	N-PE	0°										PASS
		90°		A		A		A				
		180°										
		270°	A		A		A					
DC Line												
Signal Line			A	A							PASS	

Note:

- 1) Polarity and Numbers of Impulses : 5 Pst / Ngt at each tested mode
- 2) N/A - denotes test is not applicable in this Test Report
- 3) Criteria A: There was no change operated with initial operating during the test.
- 4) Criteria B: The EUT function loss during the test, but self-recoverable after the test.
- 5) Criteria C: The system shut down during the test.



## 4.8 INJECTION CURRENT TESTING

### 4.8.1 TEST SPECIFICATION

Basic Standard:	IEC/EN IEC 61000-4-6
Required Performance	A
Frequency Range:	0.15-10 MHz, 10-30MHz, 30-80MHz
Field Strength:	3 V r.m.s, 3V to 1V r.m.s, 1V r.m.s
Modulation:	1kHz Sine Wave, 80%, AM Modulation
Frequency Step:	1 % of fundamental
Dwell Time:	at least 3 seconds

### 4.8.2 TEST PROCEDURE

The EUT and support equipment, are placed on a table that is 0.8 meter above a metal ground plane measured 1.5m\*1m min. and 0.25mm aluminum thickness.

The other condition as following manner:

- a. The frequency range is swept from 150 kHz to 80 MHz, using the signal levels (forward power) established during the setting process, and with the disturbance signal 80 % amplitude modulated with a 1 kHz sine wave, pausing to adjust the RF signal level or to change coupling devices as necessary. Where the frequency is swept incrementally, the step size shall not exceed 1 % of the preceding frequency value. The dwell time of the amplitude modulated carrier at each frequency shall not be less than the time necessary for the EUT to be exercised and to respond, but shall in no case be less than 0.5 s. Potentially sensitive frequencies shall be tested in addition to the maximum 1 % step size.



### 4.8.3 TEST SETUP

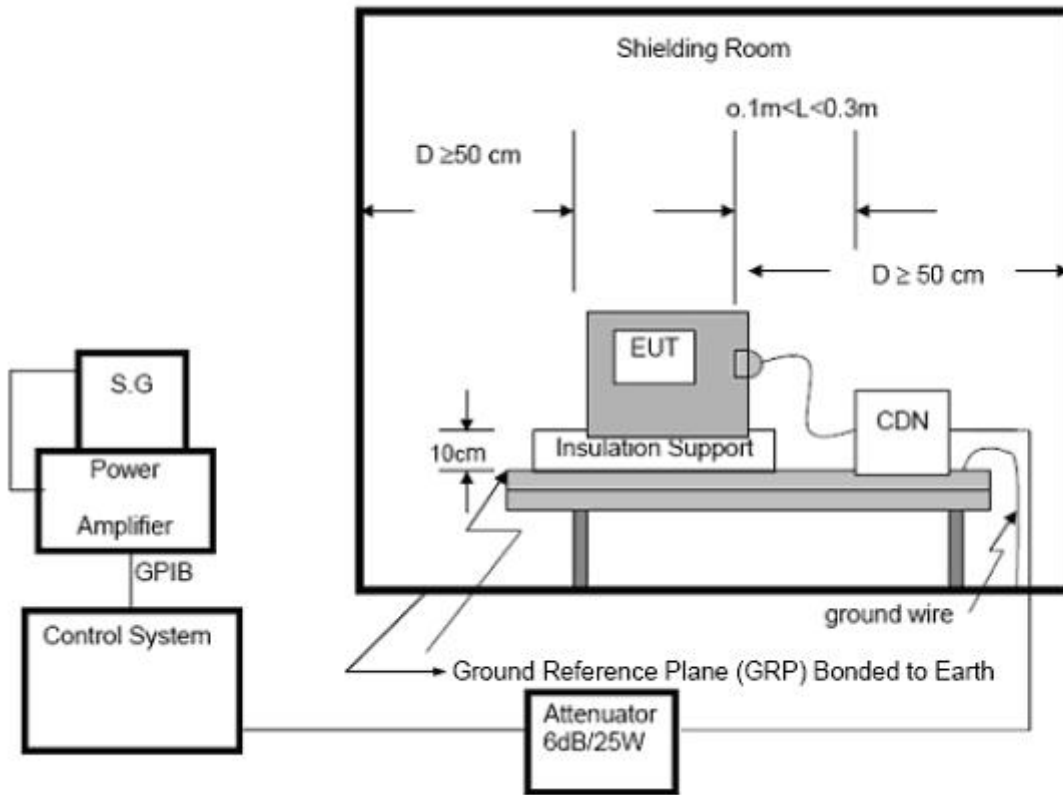

**NOTE:**

**FLOOR-STANDING EQUIPMENT**

The equipment to be tested is placed on an insulating support of 0.1 meters height above a ground reference plane. All relevant cables shall be provided with the appropriate coupling and decoupling devices at a distance between 0.1 meters and 0.3 meters from the projected geometry of the EUT on the ground reference plane.



**4.8.4 TEST RESULTS**

EUT :	CM5 AI CAMERA	Model Name :	ED-AIC3100
Temperature :	24.5 °C	Relative Humidity :	55%
Pressure :	1010 hPa	Test Date :	2026-04-08
Test Mode :	Mode 1		
Test Power :	DC 24V From Adapter		

Test Ports (Mode)	Freq. Range MHz)	Field Strength	Perform. Criteria	Results	Judgment
Input/ Output AC. Power Port	0.15 ---10	3V(rms) AM Modulated 1000Hz, 80%	A	A	PASS
	10 --- 30	3V to 1V(rms) AM Modulated 1000Hz, 80%	A	A	PASS
	30 --- 80	1V(rms) AM Modulated 1000Hz, 80%	A	A	PASS
Input/ Output DC. Power Port	0.15 ---10	3V(rms) AM Modulated 1000Hz, 80%	A	N/A	N/A
	10 --- 30	3V to 1V(rms) AM Modulated 1000Hz, 80%	A	N/A	N/A
	30 --- 80	1V(rms) AM Modulated 1000Hz, 80%	A	N/A	N/A
Signal Line	0.15 ---10	3V(rms) AM Modulated 1000Hz, 80%	A	A	PASS
	10 --- 30	3V to 1V(rms) AM Modulated 1000Hz, 80%	A	A	PASS
	30 --- 80	1V(rms) AM Modulated 1000Hz, 80%	A	A	PASS

**Note:**

- 1) N/A - denotes test is not applicable in this Test Report.
- 2) Criteria A: There was no change operated with initial operating during the test.
- 3) Criteria B: The EUT function loss during the test, but self-recoverable after the test.
- 4) Criteria C: The system shut down during the test.



## 4.9 POWER FREQUENCY MAGNETIC FIELD TESTING

### 4.9.1 TEST SPECIFICATION

Basic Standard:	IEC/EN 61000-4-8
Required Performance	A
Frequency Range:	50Hz
Field Strength:	1 A/m
Observation Time:	1 minute
Inductance Coil:	Rectangular type, 1mx1m

### 4.9.2 TEST PROCEDURE

The EUT and support equipment, are placed on a table that is 0.8 meter above a metal ground plane measured 1m\*1m min. and 0.25mm aluminum thickness.

The other condition as following manner:

- a. The equipment cabinets shall be connected to the safety earth directly on the GRP via the earth terminal of the EUT.
- b. The cables supplied or recommended by the equipment manufacturer shall be used 1 meter of all cables used shall be exposed to the magnetic field.



### 4.9.3 TEST SETUP

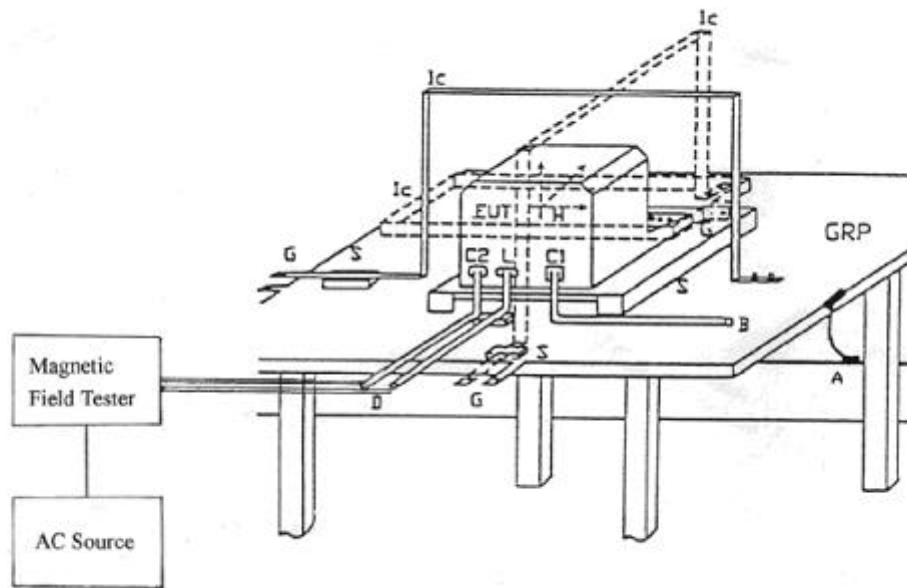

**Note:**

**TABLE-TOP EQUIPMENT**

The equipment shall be subjected to the test magnetic field by using the induction coil of standard dimension (1 m x 1 m). The induction coil shall then be rotated by 90 degrees in order to expose the EUT to the test field with different orientations.

**FLOOR-STANDING EQUIPMENT**

The equipment shall be subjected to the test magnetic field by using induction coils of suitable dimensions. The test shall be repeated by moving and shifting the induction coils, in order to test the whole volume of the EUT for each orthogonal direction. The test shall be repeated with the coil shifted to different positions along the side of the EUT, in steps corresponding to 50 % of the shortest side of the coil. The induction coil shall then be rotated by 90 degrees in order to expose the EUT to the test field with different orientations.



**4.9.4 TEST RESULTS**

EUT :	CM5 AI CAMERA	Model Name :	ED-AIC3100
Temperature :	N/A	Relative Humidity :	N/A
Pressure :	N/A	Test Date :	N/A
Test Mode :	N/A		
Test Power :	N/A		
Note: EUT is not belong containing devices intrinsically susceptible equipment, so this test report is not applicable.			



### 4.10 VOLTAGE INTERRUPTION/DIPS TESTING

#### 4.10.1 TEST SPECIFICATION

Basic Standard:	IEC/EN IEC 61000-4-11
Required Performance	B (For 100% Voltage Dips) C (For 30% Voltage Dips) C (For 100% Voltage Interruptions)
Test Duration Time:	Minimum three test events in sequence
Interval between Event:	Minimum ten seconds
Phase Angle:	0°/45°/90°/135°/180°/225°/270°/315°/360°
Test Cycle:	3 times

#### 4.10.2 TEST PROCEDURE

The EUT shall be tested for each selected combination of test level and duration with a sequence of three dips/interruptions with intervals of 10 s minimum (between each test event). Each representative mode of operation shall be tested.

#### 4.10.3 TEST SETUP

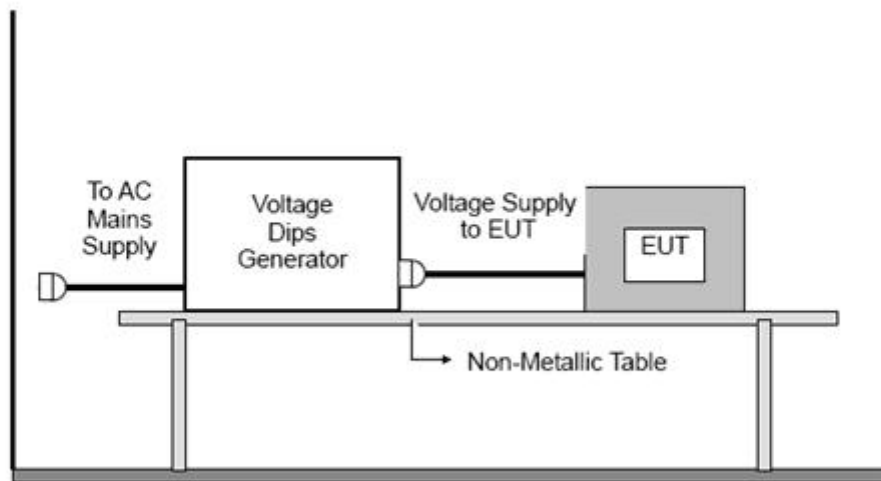



**4.10.4 TEST RESULTS**

EUT :	CM5 AI CAMERA	Model Name :	ED-AIC3100
Temperature :	24.5 °C	Relative Humidity :	55%
Pressure :	1010 hPa	Test Date :	2026-04-08
Test Mode :	Mode 1		
Test Power :	DC 24V From Adapter		

Interruption & Dips	Duration (T)	Perform Criteria	Results	Judgment
Voltage dip 100%	0.5	<b>B</b>	<b>A</b>	<b>PASS</b>
Voltage dip 30%	25	<b>C</b>	<b>A</b>	<b>PASS</b>
Voltage dip 100%	250	<b>C</b>	<b>C</b>	<b>PASS</b>

**Note:**

- 1). N/A - denotes test is not applicable in this test report.
- 2) Criteria A: There was no change operated with initial operating during the test.
- 3) Criteria B: The EUT function loss during the test, but self-recoverable after the test.
- 4) Criteria C: The system shut down during the test.



**HUAKE TESTING**

### 5. EUT TEST PHOTO

#### Conducted Emission



#### Conducted Emission (Telecommunication port)



The results shown in this test report refer only to the sample(s) tested unless otherwise stated and the sample(s) are retained for 15 days only. The document is issued by Shenzhen HUAKE Testing Technology Co., Ltd., this document cannot be reproduced except in full with our prior written permission.

### Radiated Emission

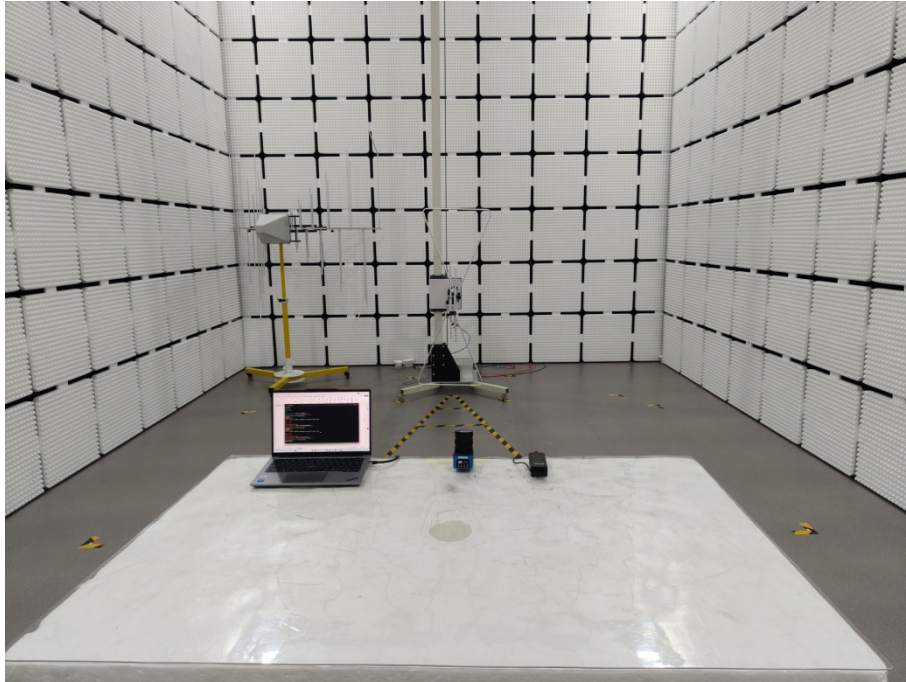

### Flicker

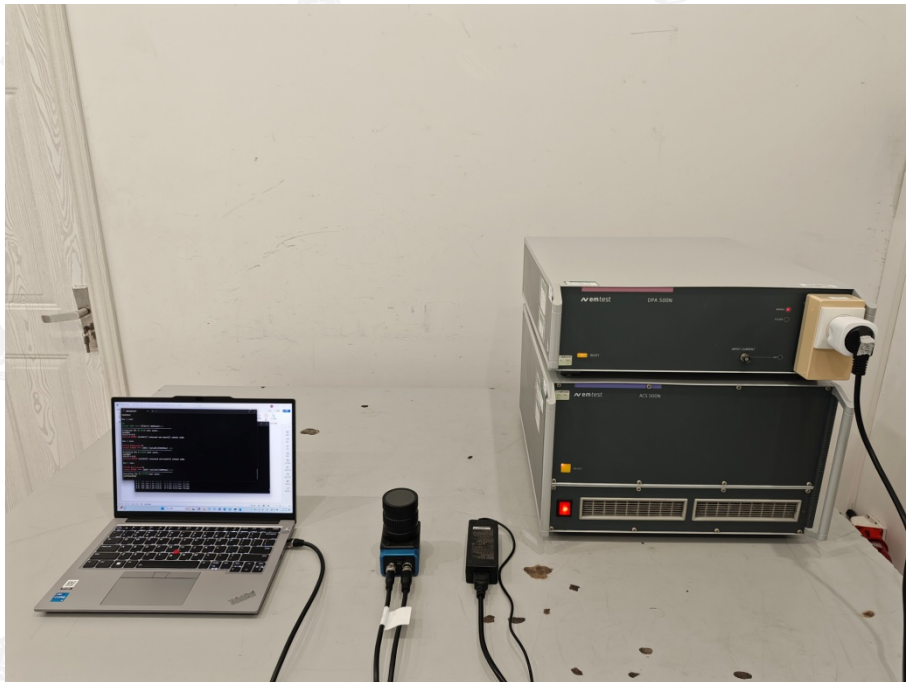

The results shown in this test report refer only to the sample(s) tested unless otherwise stated and the sample(s) are retained for 15 days only. The document is issued by Shenzhen HUAKE Testing Technology Co., Ltd., this document cannot be reproduced except in full with our prior written permission.

### Electrostatic Discharge



### RF electromagnetic field

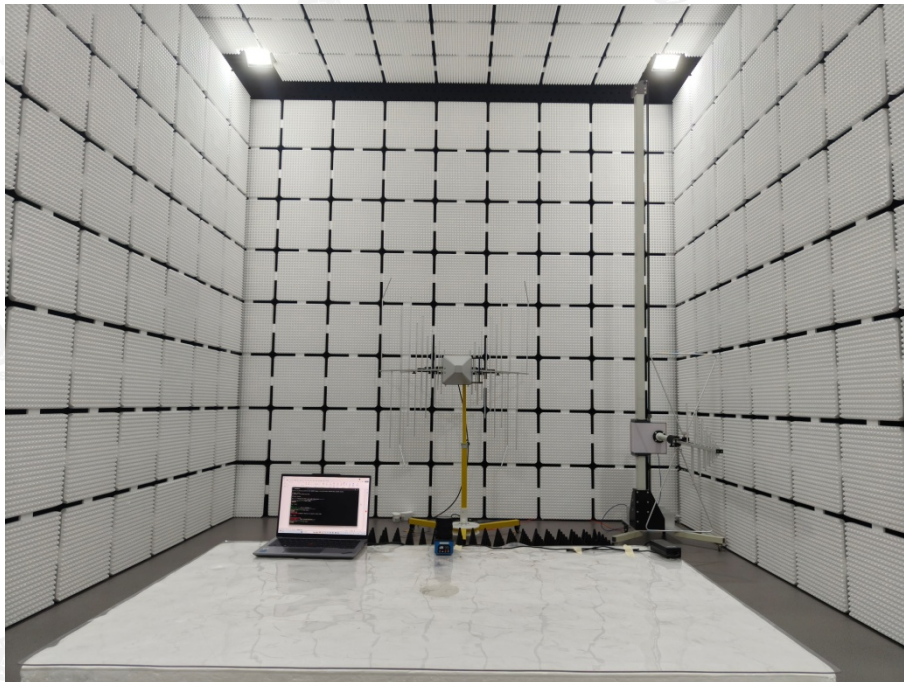

The results shown in this test report refer only to the sample(s) tested unless otherwise stated and the sample(s) are retained for 15 days only. The document is issued by Shenzhen HUAKE Testing Technology Co., Ltd., this document cannot be reproduced except in full with our prior written permission.

### EFT & Surge & Voltage Dips



### Injected Current



The results shown in this test report refer only to the sample(s) tested unless otherwise stated and the sample(s) are retained for 15 days only. The document is issued by Shenzhen HUAK Testing Technology Co., Ltd., this document cannot be reproduced except in full with our prior written permission.

ATTACHMENT PHOTOGRAPHS OF EUT

Photo 1



Photo 2



Photo 3

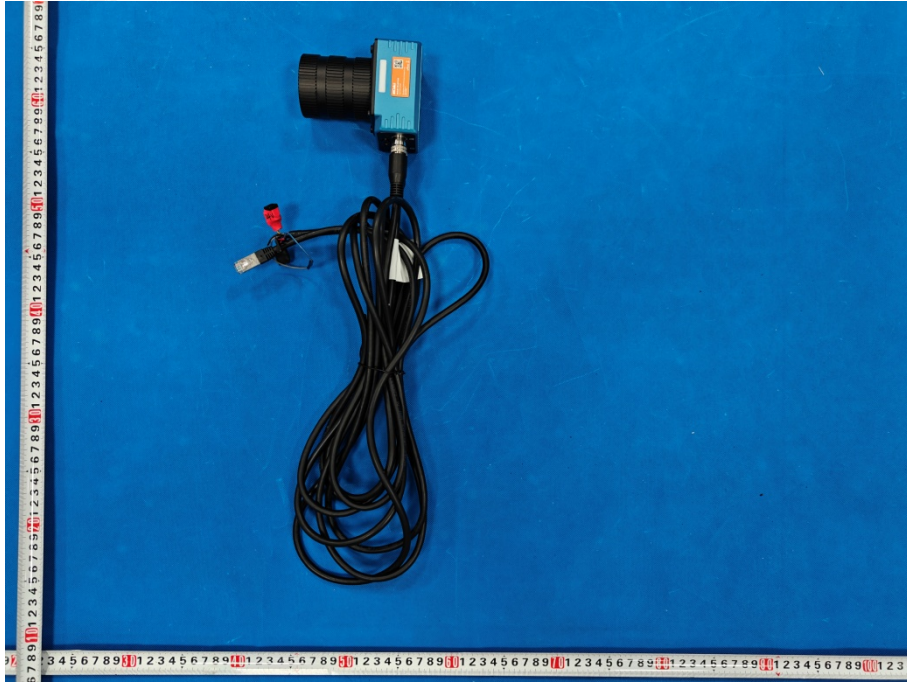

Photo 4

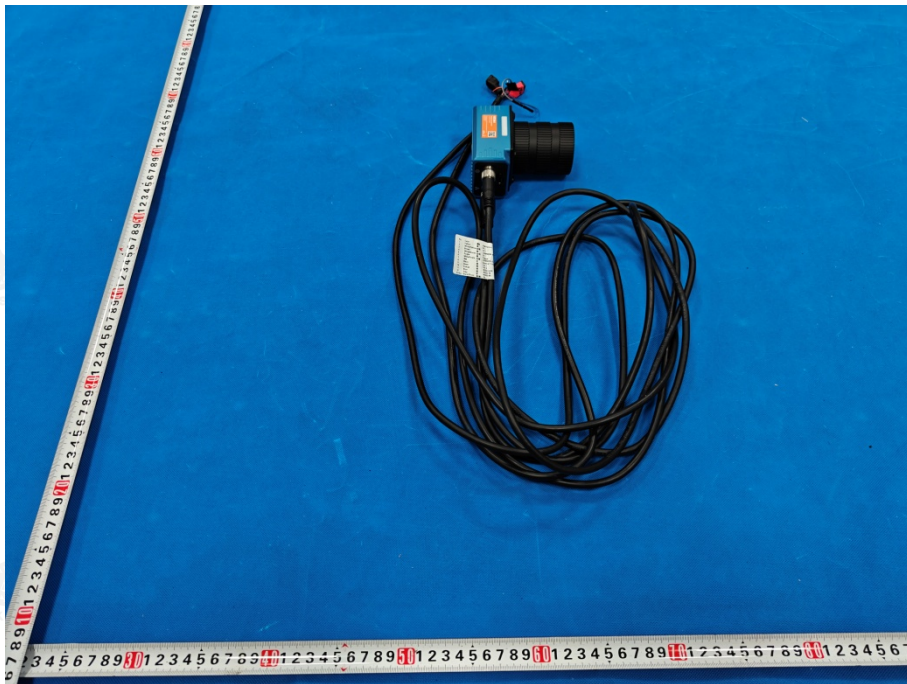

Photo 5



Photo 6

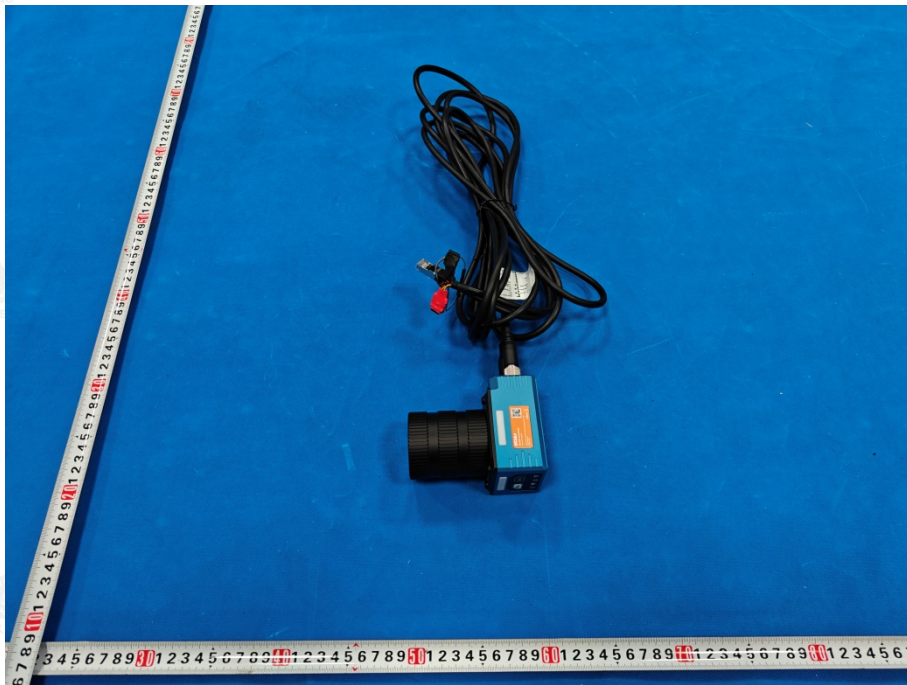

Photo 7

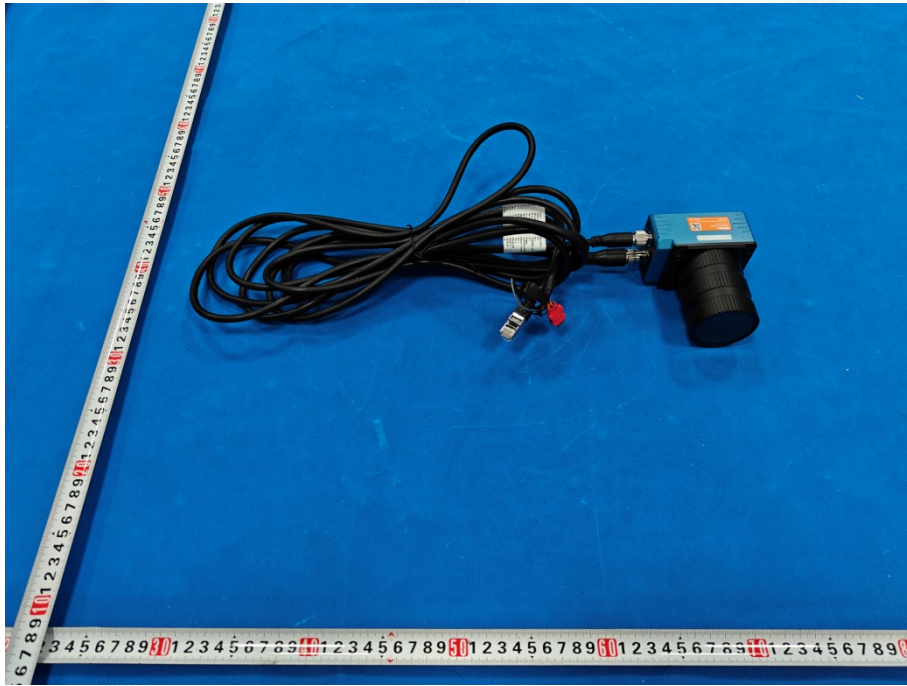

Photo 8

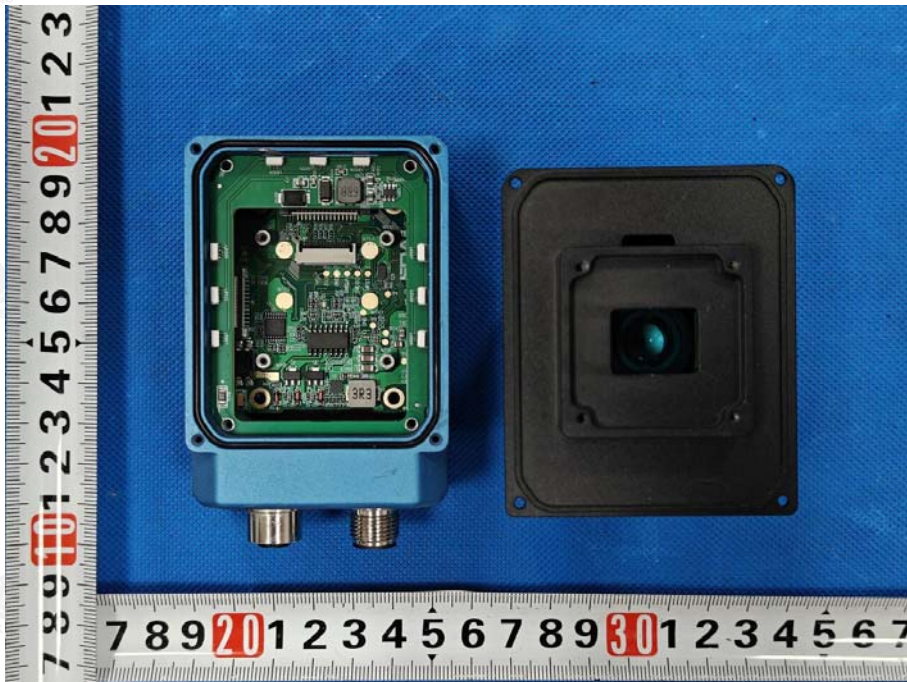

Photo 9

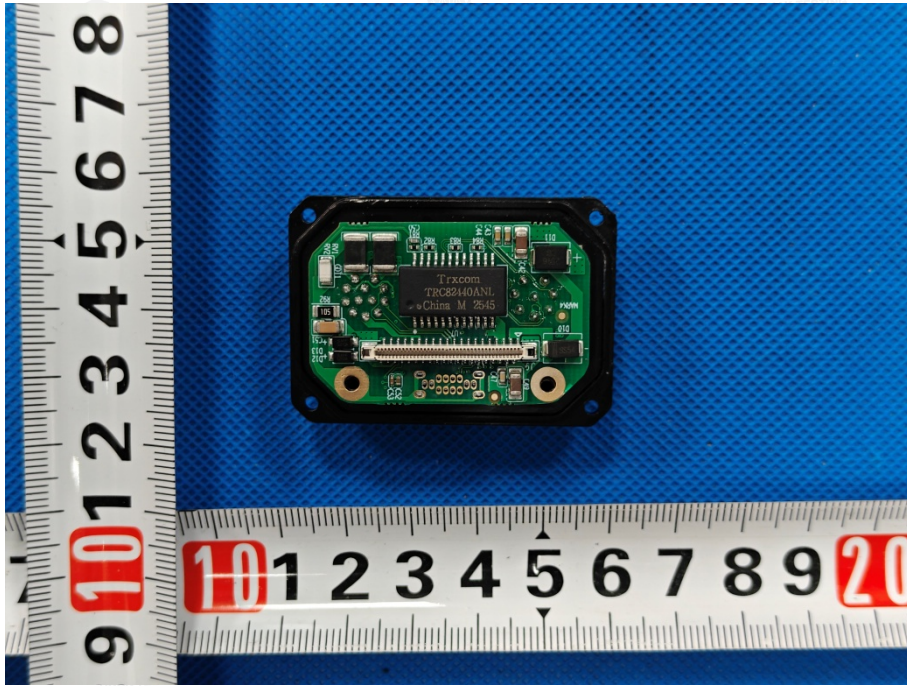
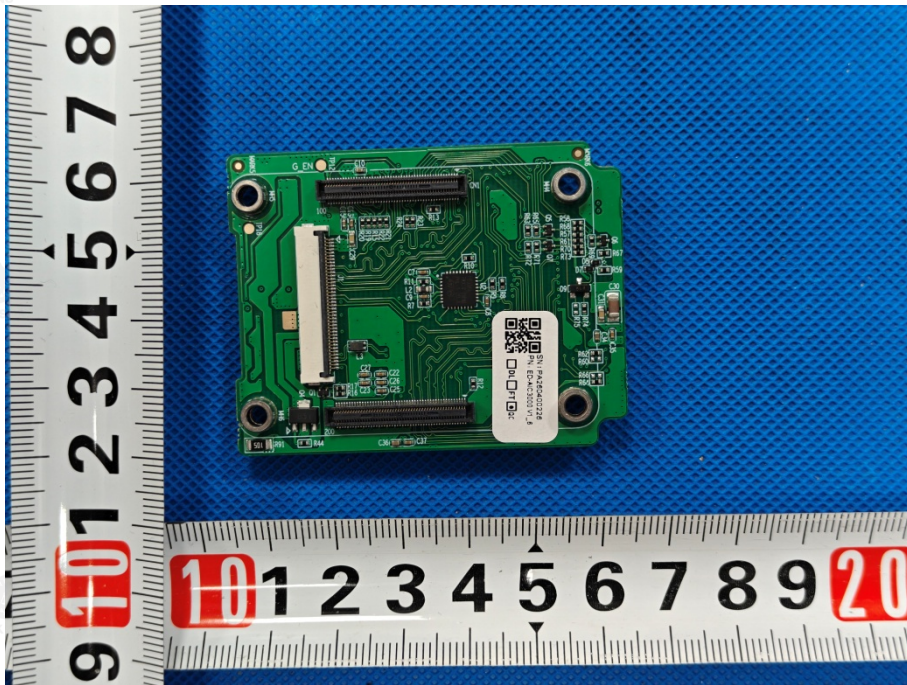

Photo 10



The results shown in this test report refer only to the sample(s) tested unless otherwise stated and the sample(s) are retained for 15 days only. The document is issued by Shenzhen HUAK Testing Technology Co., Ltd., this document cannot be reproduced except in full with our prior written permission.

Photo 11

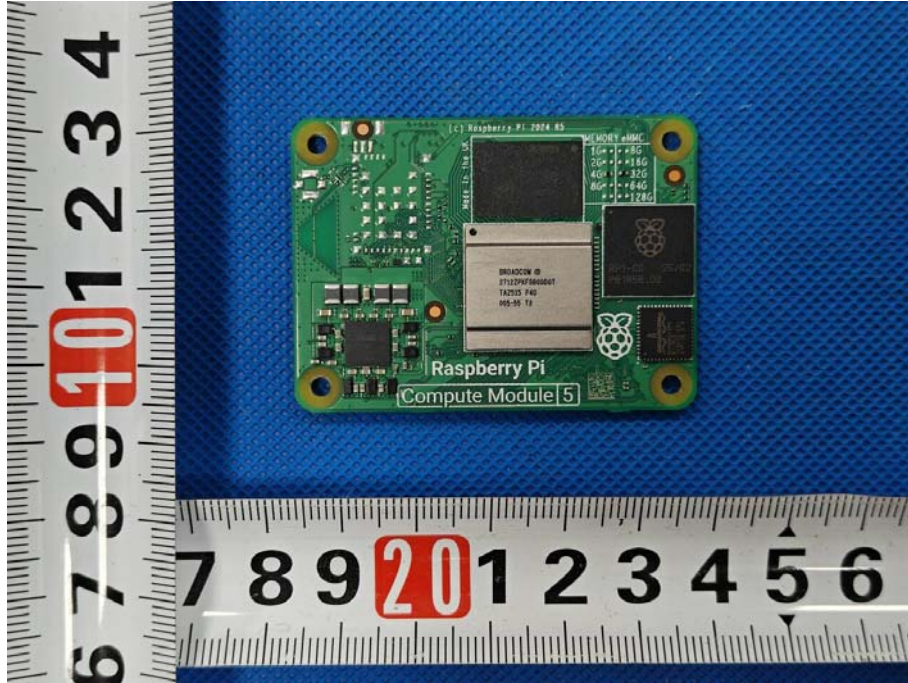

Photo 12

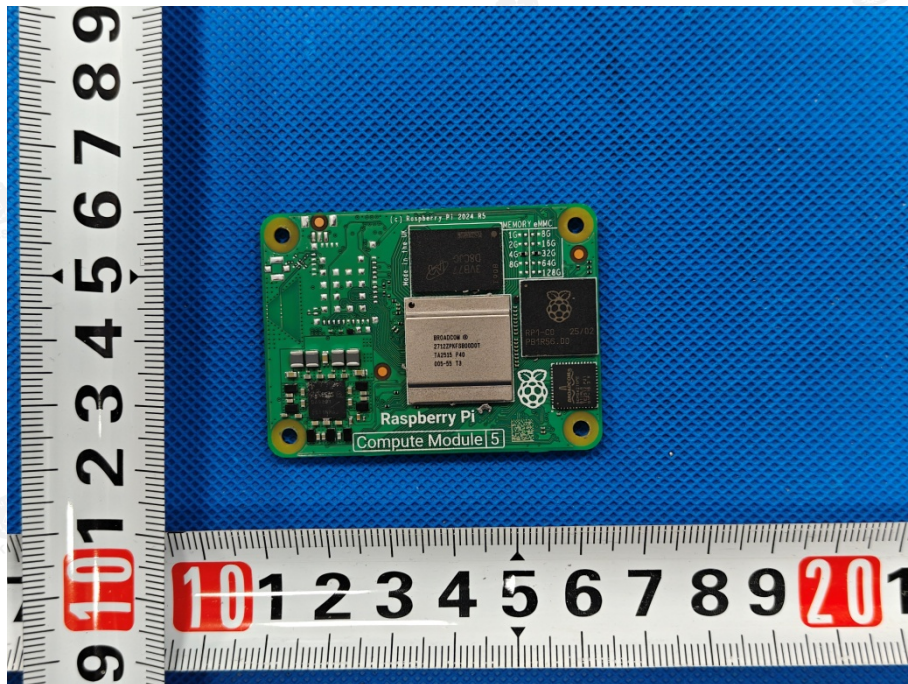

Photo 13

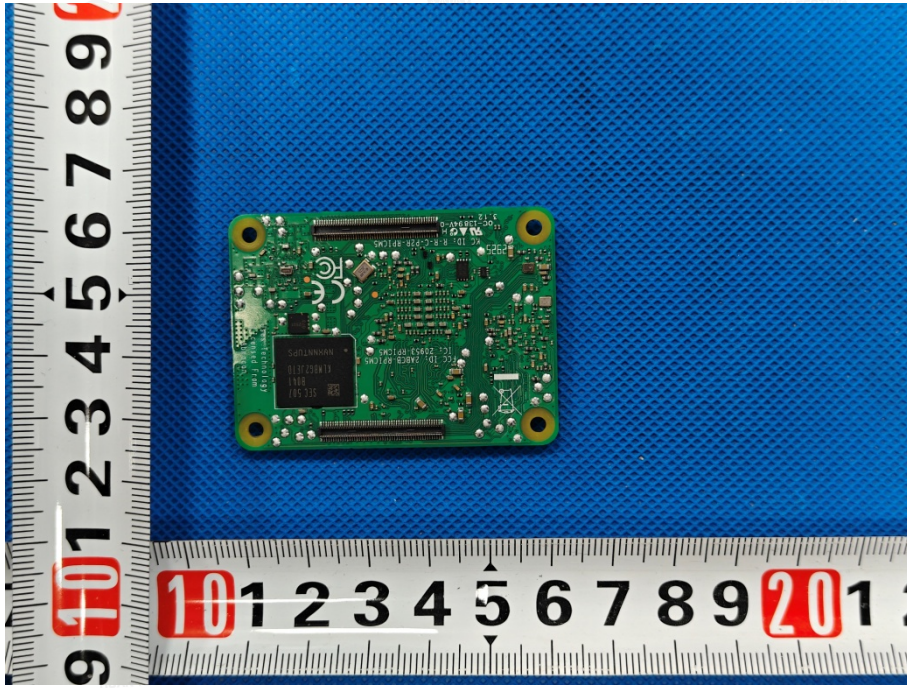

Photo 14

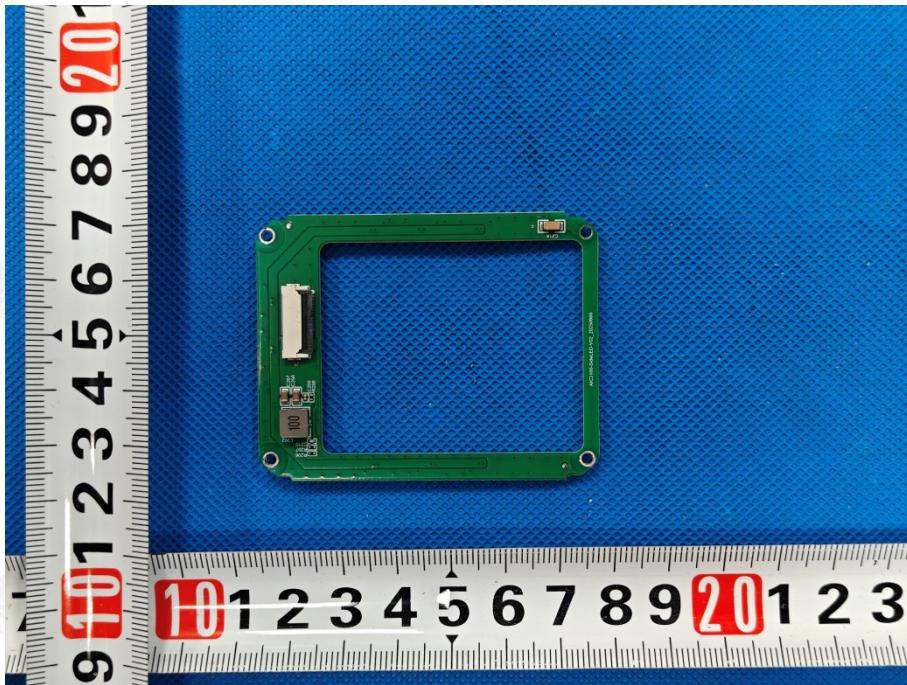

Photo 15

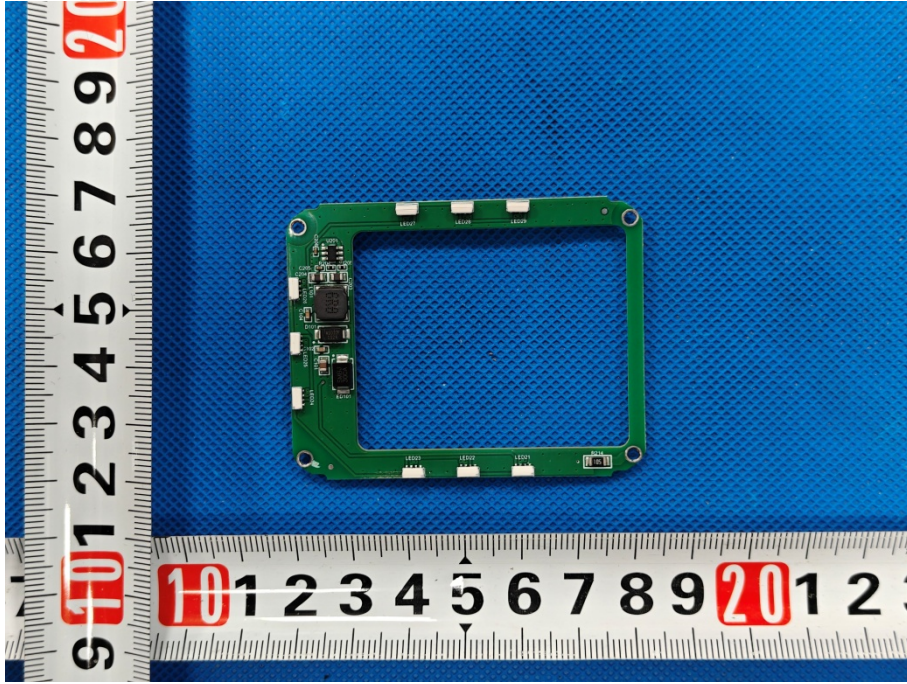
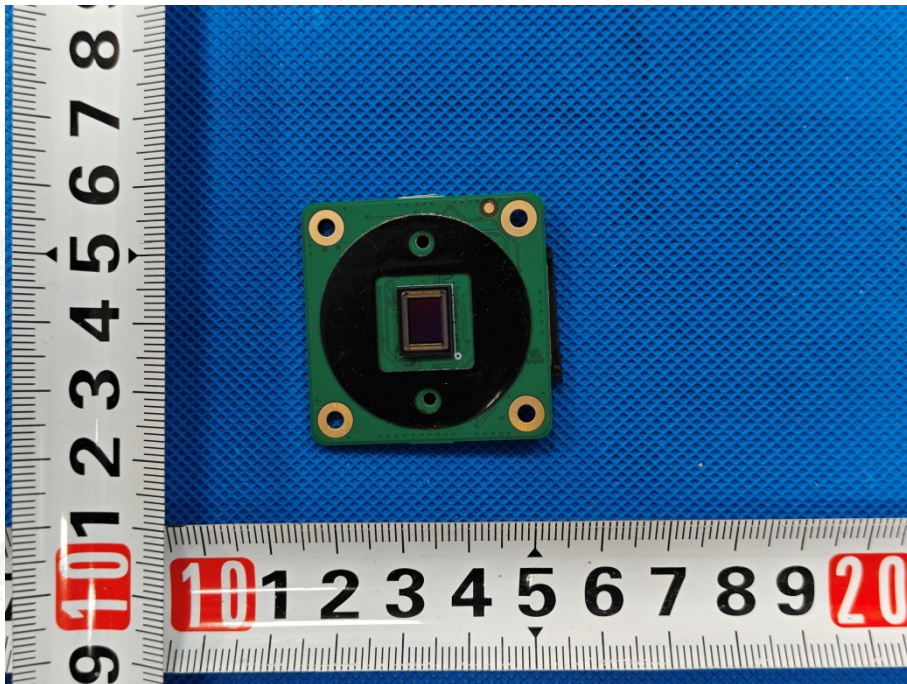

Photo 16



The results shown in this test report refer only to the sample(s) tested unless otherwise stated and the sample(s) are retained for 15 days only. The document is issued by Shenzhen HUAKE Testing Technology Co., Ltd., this document cannot be reproduced except in full with our prior written permission.

Photo 17

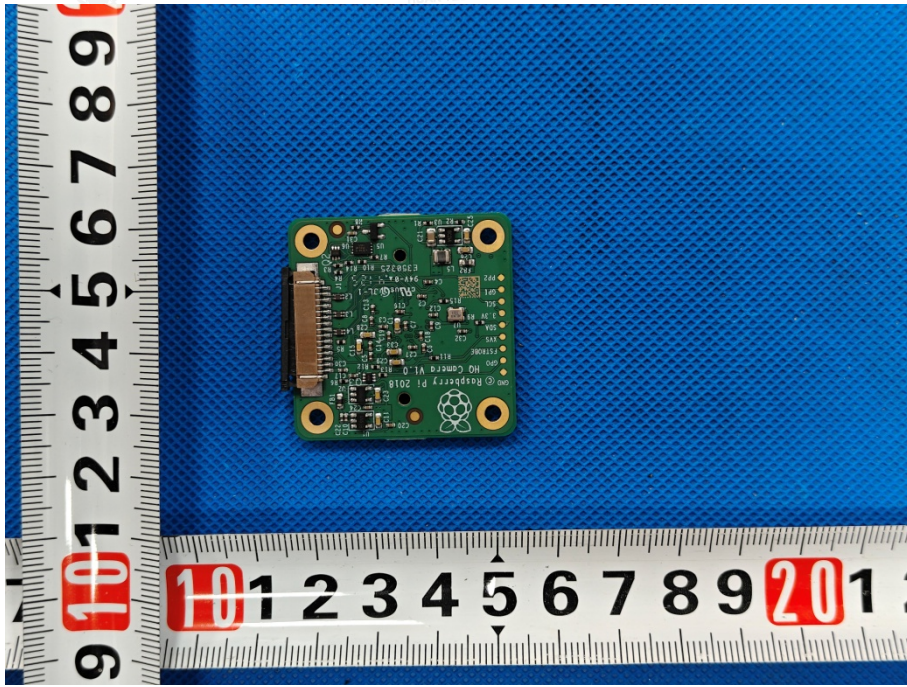

Photo 18



-----End of report-----

The results shown in this test report refer only to the sample(s) tested unless otherwise stated and the sample(s) are retained for 15 days only. The document is issued by Shenzhen HUAKE Testing Technology Co., Ltd., this document cannot be reproduced except in full with our prior written permission.